

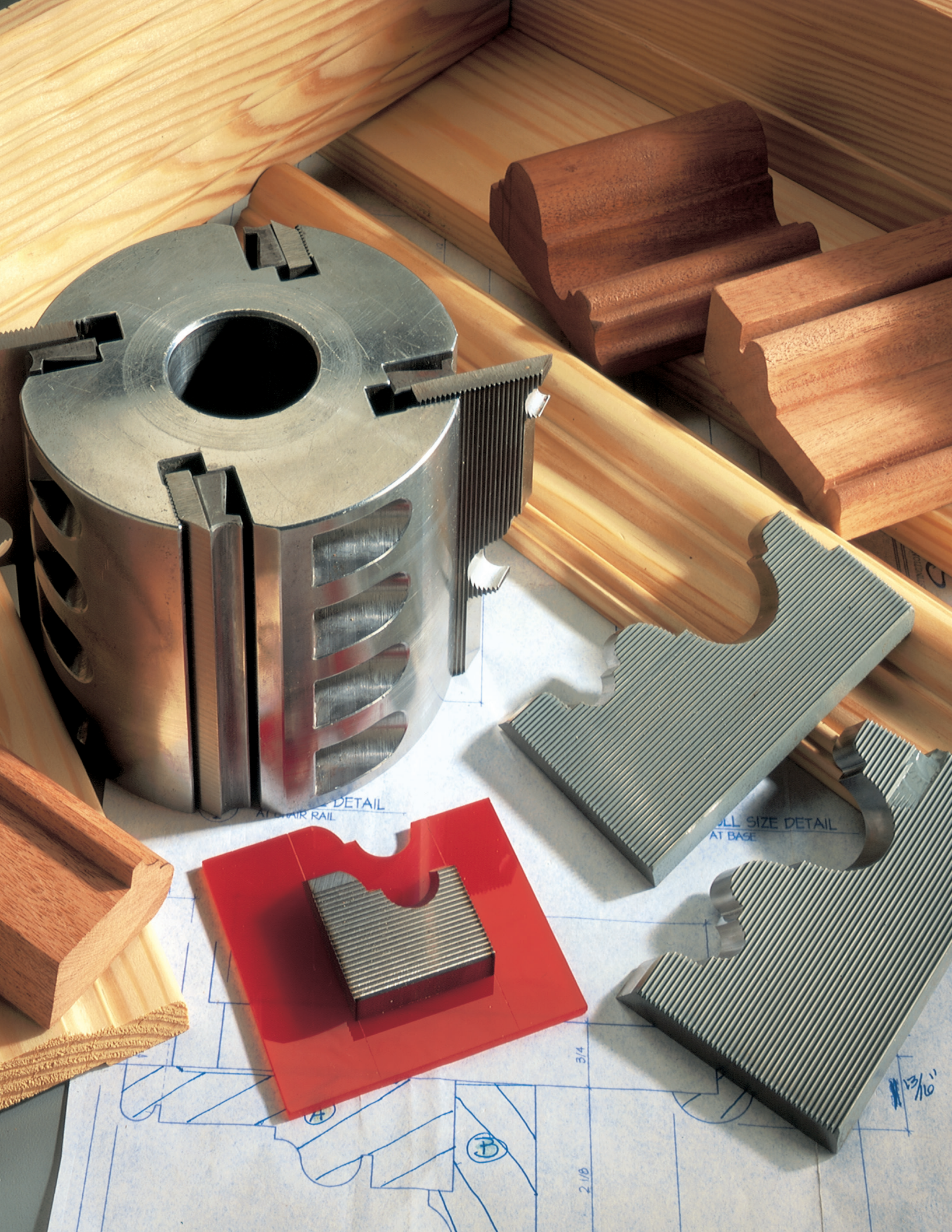

Stephenson

MILLWORK COMPANY, INC.

**MOULDING
CATALOGUE**
FIFTH EDITION



DETAIL
AT CHAIR RAIL

FULL SIZE DETAIL
AT BASE

3/4

2 1/8

13/16"



About our company and this catalogue

For more than a half century, we at Stephenson Millwork have prided ourselves on producing woodwork of distinction. From the beginning, high quality mouldings have been a cornerstone of our spectrum of millwork products.

Our customers have come to rely on our ability to provide a wide selection of traditional moulding profiles. We possess the capacity to produce unique mouldings that reflect a particular architectural direction as well as represent special custom design requirements. We stock a wide selection of premium lumber species in multiple dimensions, which allows us to respond quickly to a broad range of customer needs.

This catalogue has been produced to assist architects, designers, builders and home owners as they consider moulding choices and combinations. Each section contains an overview, followed by a scale drawing of each pattern.

TABLE OF CONTENTS

CASING & BACKBAND	2-10
PLINTH BLOCKS.	11
WINDOW STOOL, APRON & STOP.	12-14
BED, CROWN & COVE.	15-20
LARGE CROWNS & COVES.	21-24
DENTIL MOULDING	25
CORNICE COMBINATION	26-27
CONTEMPORARY MOULDING	28
BASEBOARD & BASE CAP.	29-31
CHAIR RAIL & CHAIR RAIL BACKER.	32-33
EXTERIOR MOULDING.	34-36
MODILLION BLOCK & PLATE	37
BEADED/EDGE TRIM & RAKE	38
PILASTERS	39
MANTLE MOULDING	40-41
HANDRAIL	42-43
CORNER MOULDING	44-45
PANELING & FLOORING.	46-48
MISCELLANEOUS MOULDINGS.	49
INDEX	50-51

WILSON

P.O. Box 699 • 210 Harper Street • Wilson, NC 27894

Tel: 252-237-1141 • Fax: 252-237-4377

RALEIGH

1053 E. Whitaker Mill Road, Suite 165 • Raleigh, NC 27604

Tel: 919-829-1005 • Fax: 919-829-7030

email: smc@smcinc.com web: www.smcinc.com

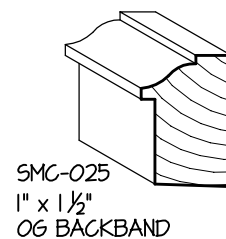
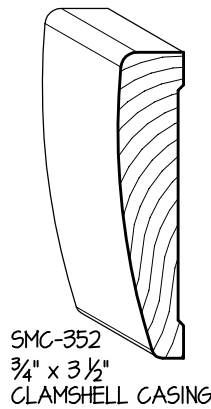
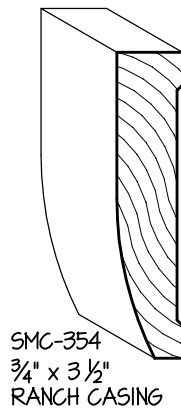
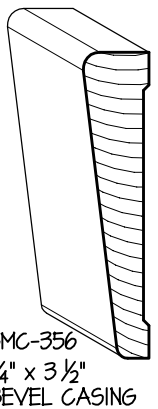
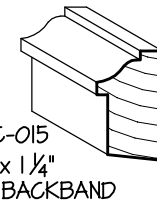
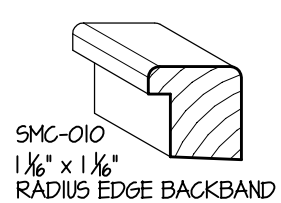
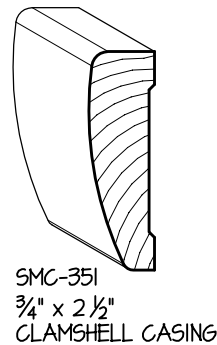
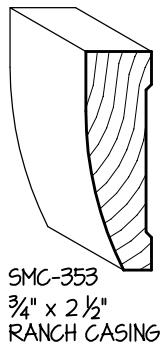
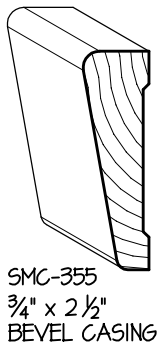
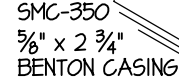
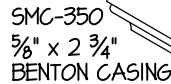
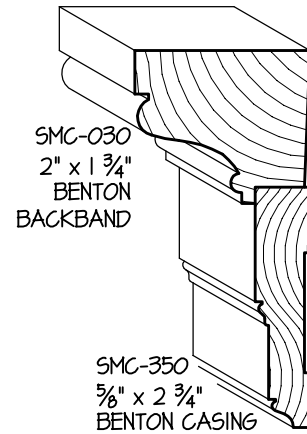
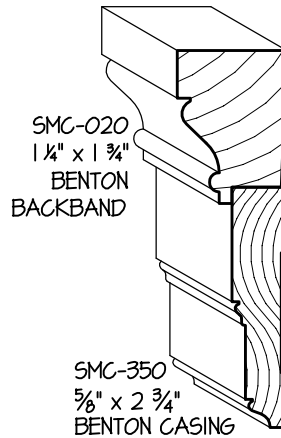
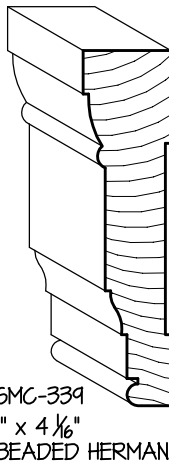
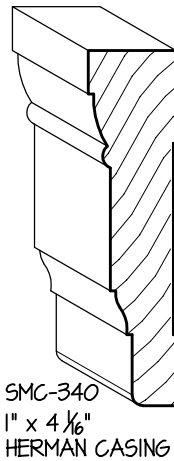
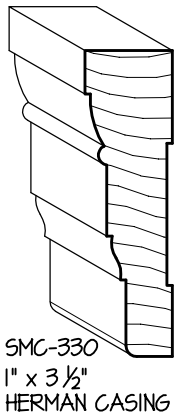
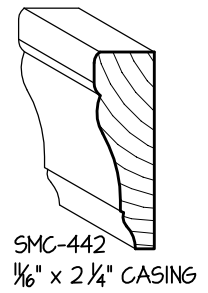
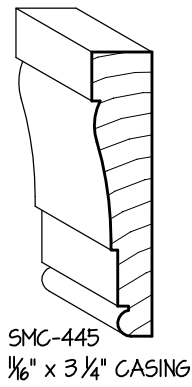
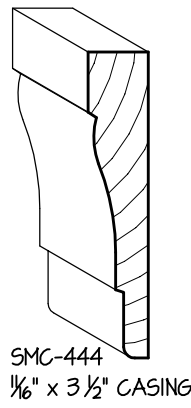
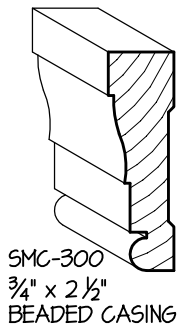
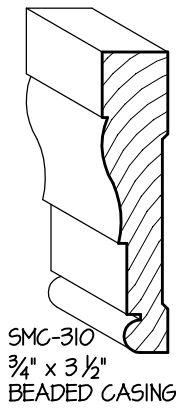
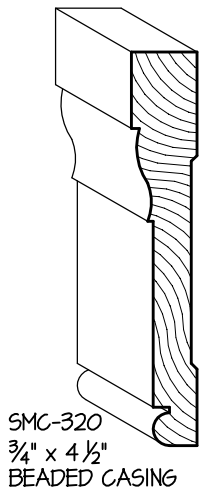

THIS PAGE NOT TO SCALE

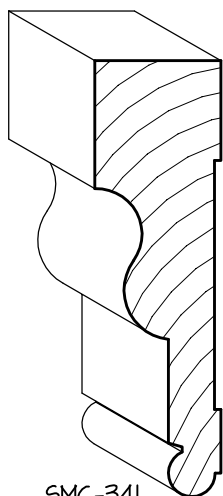

SMC-341
1 1/4" x 4 3/8" CASING

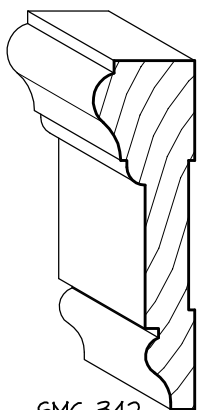

SMC-342
1" x 3 1/2" CASING

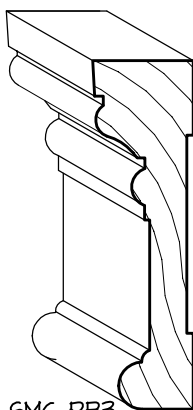

SMC-RB3
1" x 3 1/2" CASING

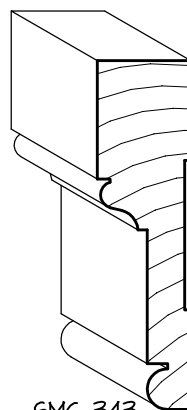

SMC-343
1" x 3 1/2" CASING

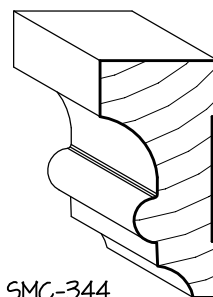

SMC-344
1 1/4" x 2 3/8" CASING

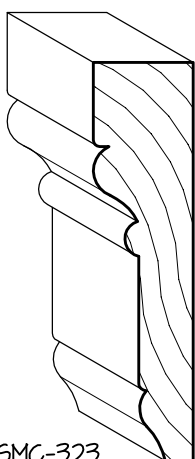

SMC-323
1" x 4"
GLENWOOD CASING

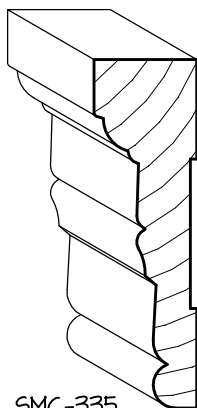

SMC-335
1" x 3 1/2"
FRANKLIN CASING

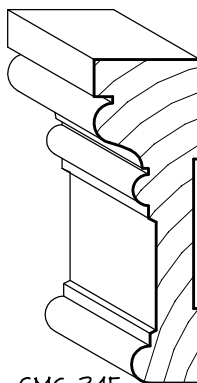

SMC-345
1" x 3 1/4" CASING

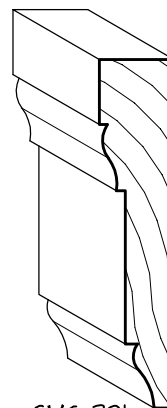

SMC-321
3/4" x 3 1/2"
OG CASING

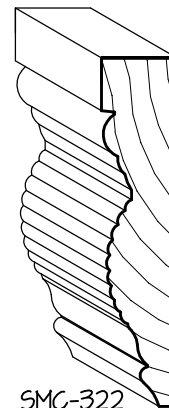

SMC-322
3/4" x 3 1/2"
REEDED CASING

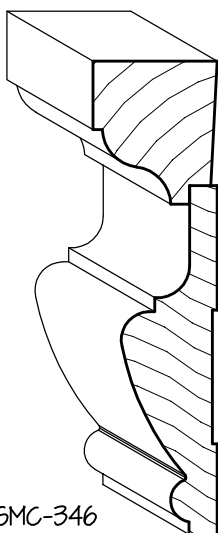

SMC-346
1" x 3 1/2" BARRUS CASING
SMC-346B
1 1/4" x 1 1/2" BARRUS BACKBAND

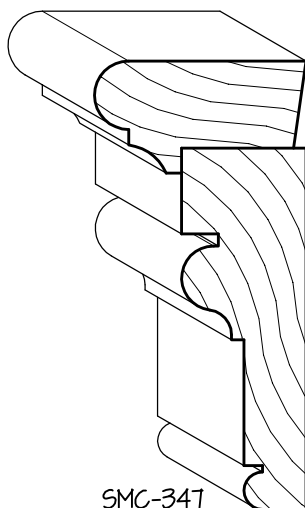

SMC-347
1 1/4" x 3 5/8" CASING
SMC-026
7/8" x 2 1/8" BACKBAND

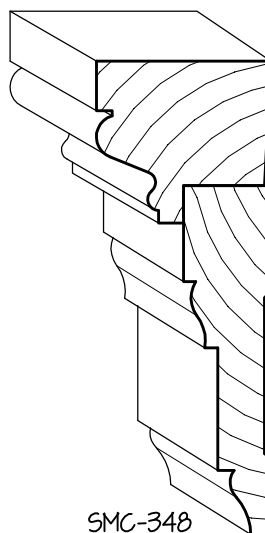

SMC-348
7/8" x 3 1/2" CASING
SMC-027
1 3/4" x 1 5/8" BACKBAND

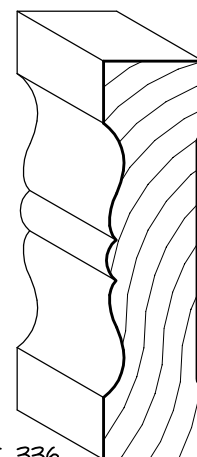

SMC-336
1" x 4"
COAST GUARD CASING

THIS PAGE NOT TO SCALE



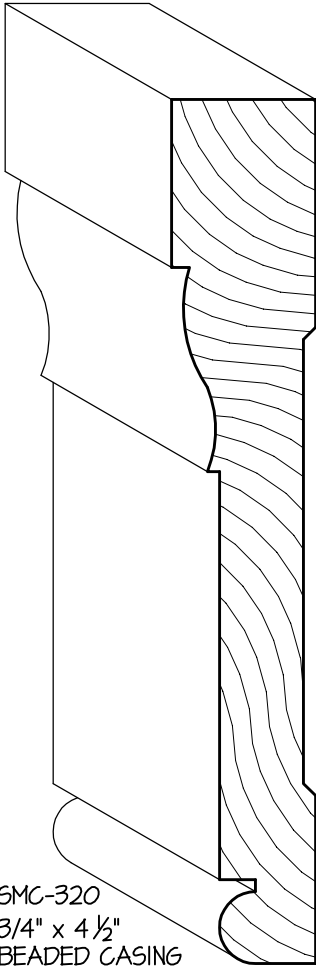

SMC-320
3/4" x 4 1/2"
BEADED CASING

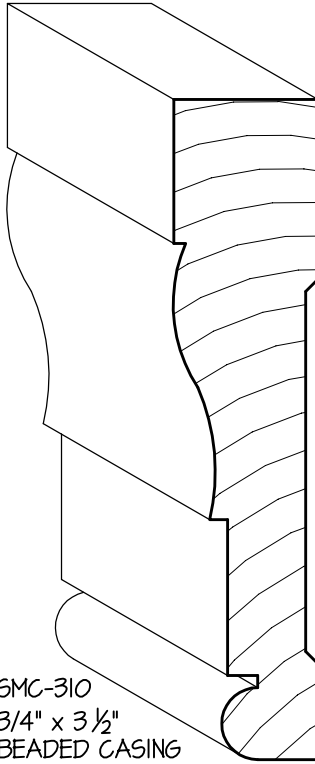

SMC-310
3/4" x 3 1/2"
BEADED CASING

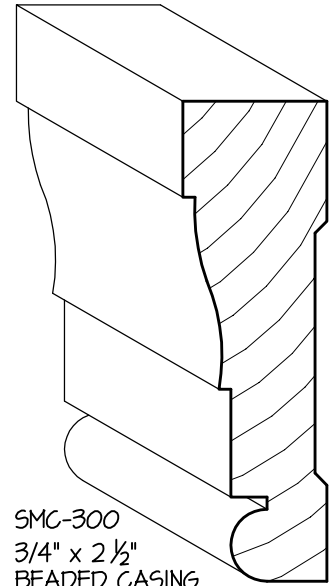

SMC-300
3/4" x 2 1/2"
BEADED CASING

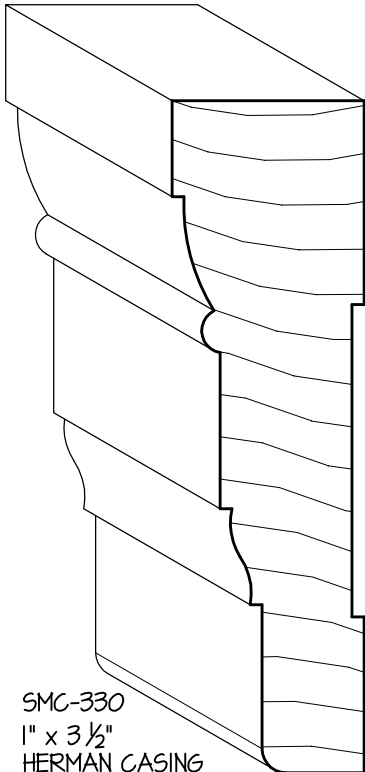

SMC-330
1" x 3 1/2"
HERMAN CASING

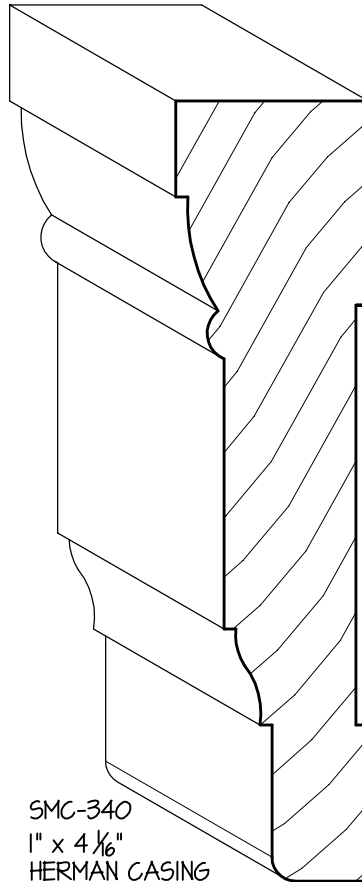

SMC-340
1" x 4 1/16"
HERMAN CASING

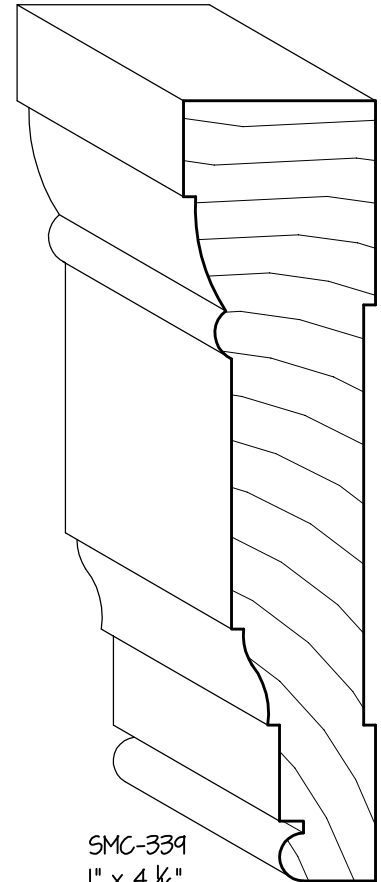

SMC-339
1" x 4 1/16"
BEADED HERMAN CASING

FULL SIZE

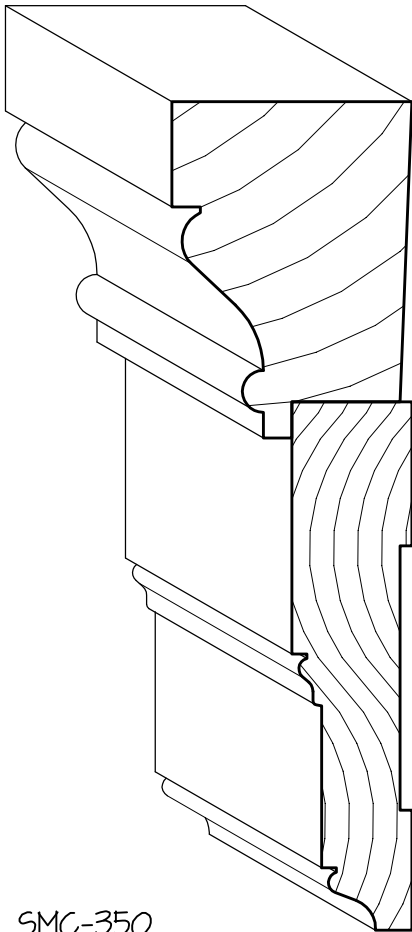

SMC-350
 $\frac{5}{8}$ " x $2 \frac{3}{4}$ " BENTON CASING
 SMC-020
 $1 \frac{1}{4}$ " x $1 \frac{3}{4}$ " BENTON BACKBAND

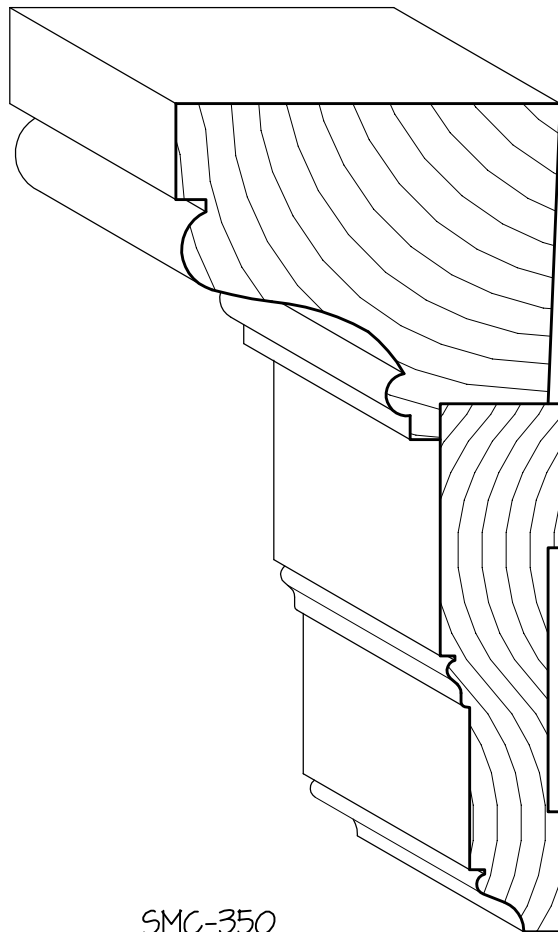

SMC-350
 $\frac{5}{8}$ " x $2 \frac{3}{4}$ " BENTON CASING
 SMC-030
 2 " x $1 \frac{3}{4}$ " BENTON BACKBAND

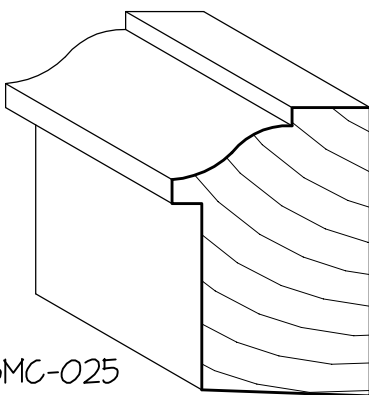

SMC-025
 1 " x $1 \frac{1}{2}$ "
 OG BACKBAND

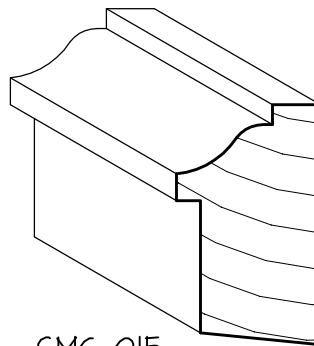

SMC-015
 $\frac{3}{4}$ " x $1 \frac{1}{4}$ "
 OG BACKBAND

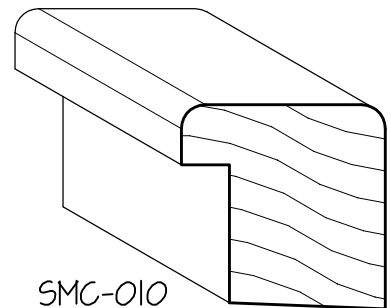

SMC-010
 $1 \frac{1}{16}$ " x $1 \frac{1}{16}$ "
 RADIUS EDGE BACKBAND



SMC-355 $\frac{3}{4}$ " x $2\frac{1}{2}$ "
 SMC-356 $\frac{3}{4}$ " x $3\frac{1}{2}$ "
 BEVEL CASING

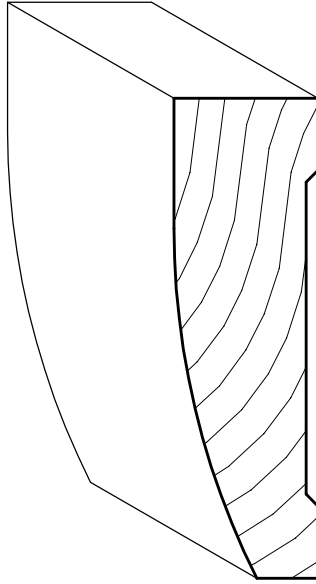

SMC-353 $\frac{3}{4}$ " x $2\frac{1}{2}$ "
 SMC-354 $\frac{3}{4}$ " x $3\frac{1}{2}$ "
 RANCH CASING

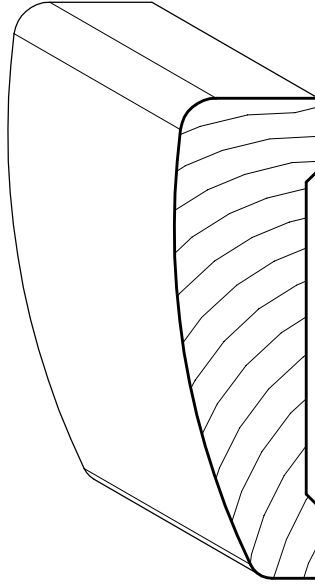

SMC-351 $\frac{3}{4}$ " x $2\frac{1}{2}$ "
 SMC-352 $\frac{3}{4}$ " x $3\frac{1}{2}$ "
 CLAMSHELL CASING

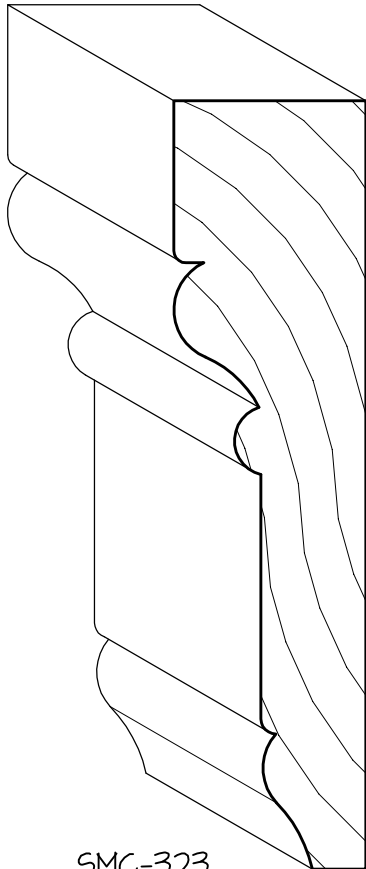

SMC-323
 1" x 4" GLENWOOD CASING

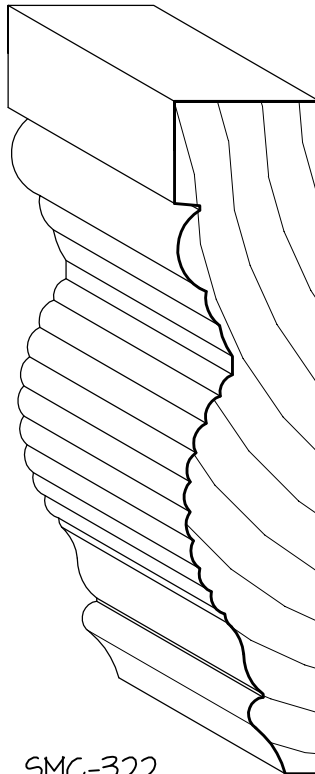

SMC-322
 $\frac{3}{4}$ " x $3\frac{1}{2}$ " REEDED CASING

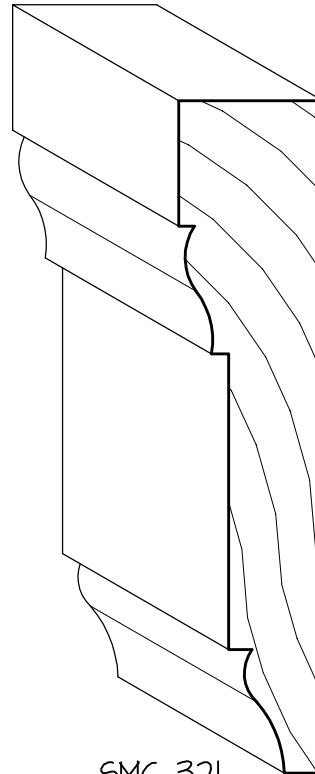

SMC-321
 $\frac{3}{4}$ " x $3\frac{1}{2}$ " OG CASING

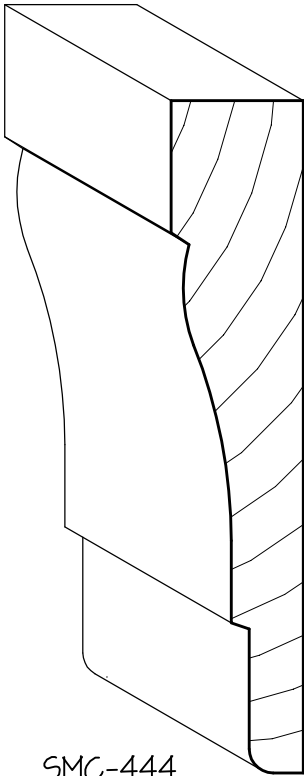

SMC-444
1/16" x 3 1/2" CASING

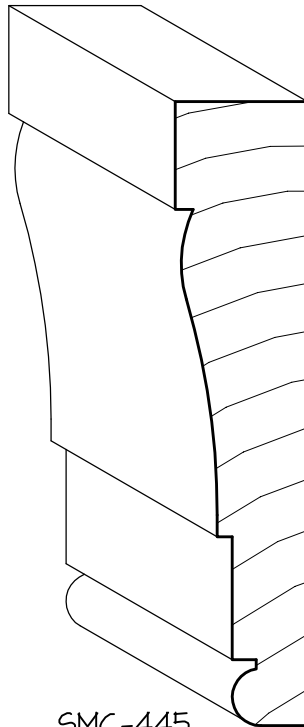

SMC-445
1/16" x 3 1/4" CASING

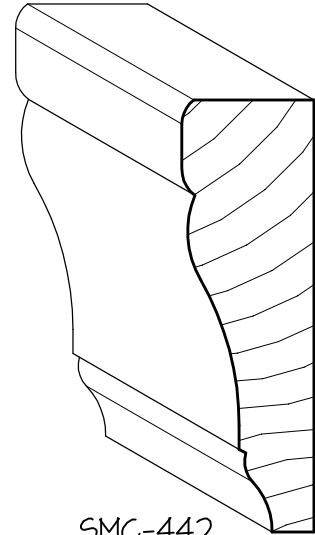

SMC-442
1/16" x 2 1/4" CASING

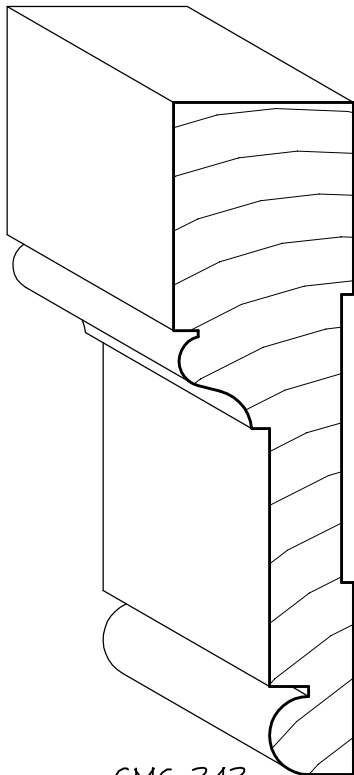

SMC-343
1" x 3 1/2" CASING

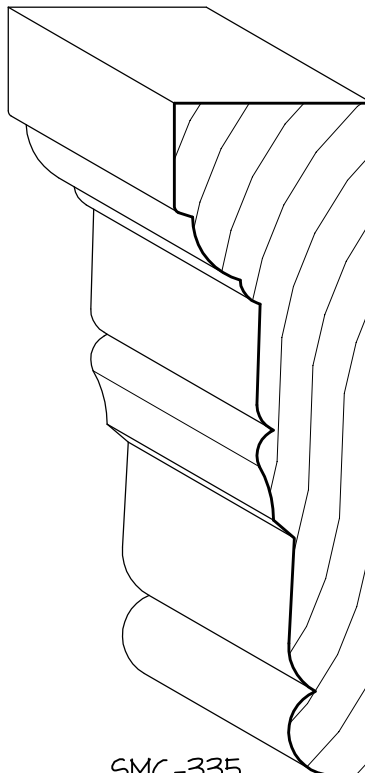

SMC-335
1" x 3 1/2" FRANKLIN CASING

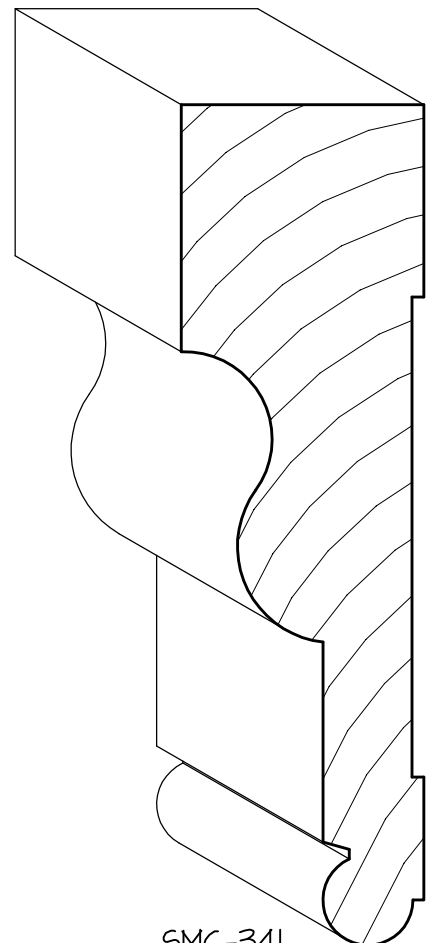

SMC-341
1/4" x 4 3/8" CASING

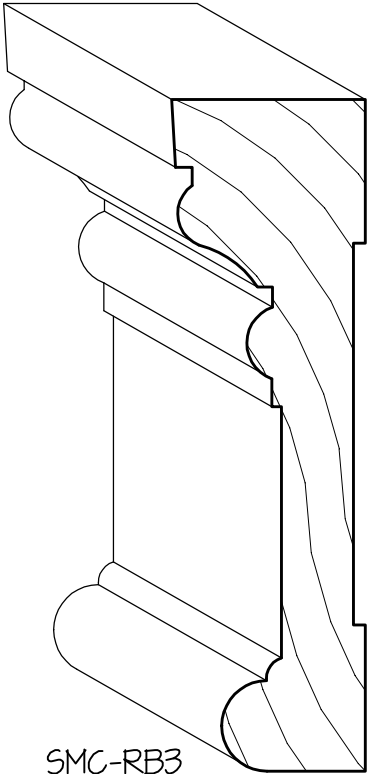

SMC-RB3
1" x 3 1/2" CASING

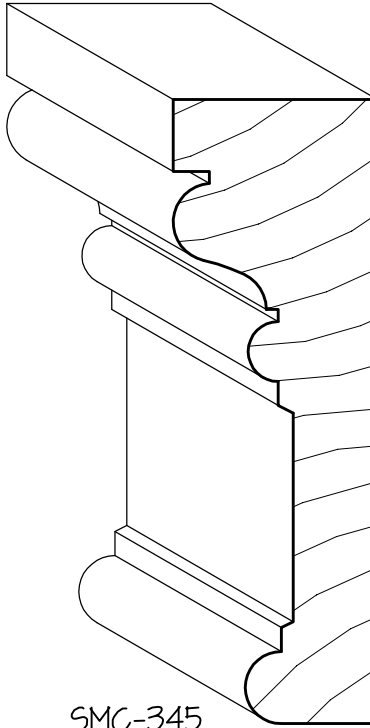

SMC-345
1" x 3 1/4" CASING

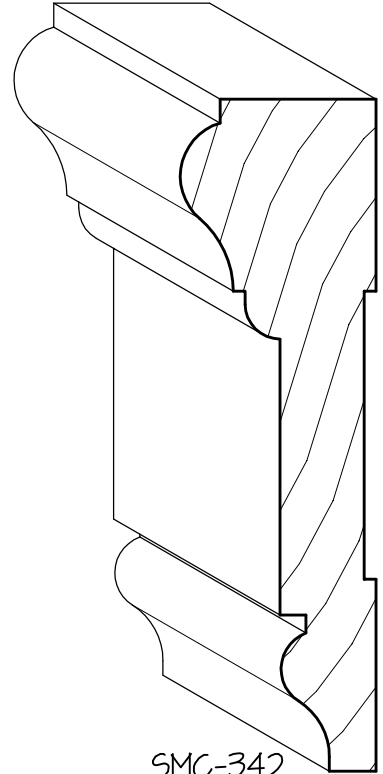

SMC-342
1" x 3 1/2" CASING



SMC-336
1" x 4" COAST GUARD CASING

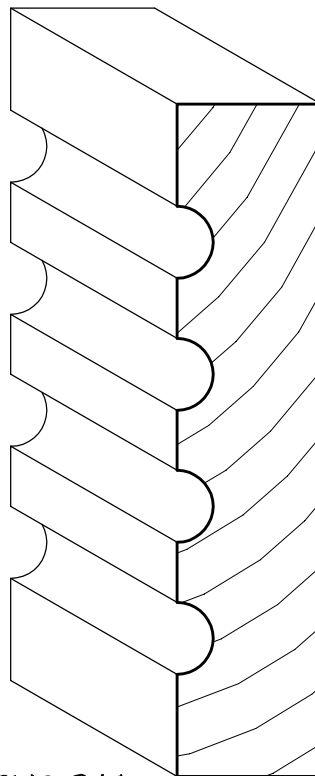

SMC-349
3/4" x 3 1/2" FLUTED CASING

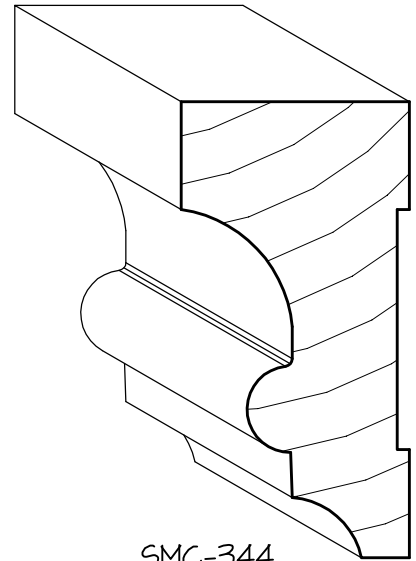

SMC-344
1 1/4" x 2 3/8" CASING

FULL SIZE

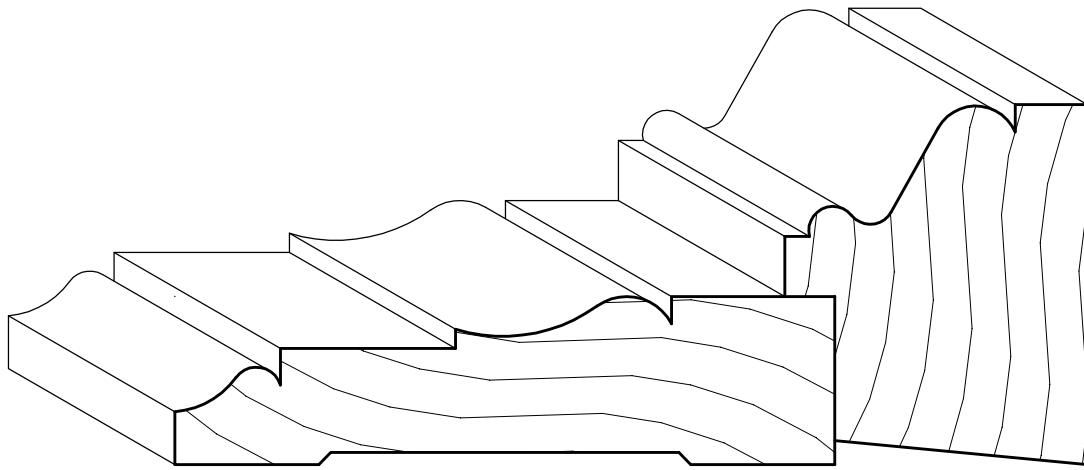

SMC-348
 $\frac{1}{8}$ " x $3\frac{1}{16}$ " CASING

SMC-027
 $1\frac{1}{8}$ " x $1\frac{9}{16}$ " BACKBAND

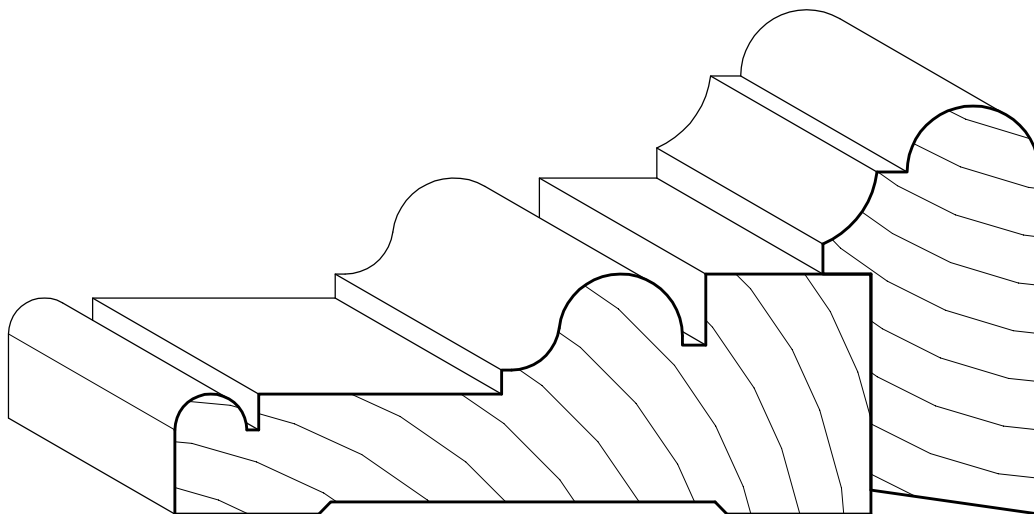

SMC-347
 $1\frac{1}{4}$ " x $3\frac{5}{8}$ " CASING

SMC-026
 $1\frac{1}{8}$ " x $2\frac{1}{8}$ " BACKBAND

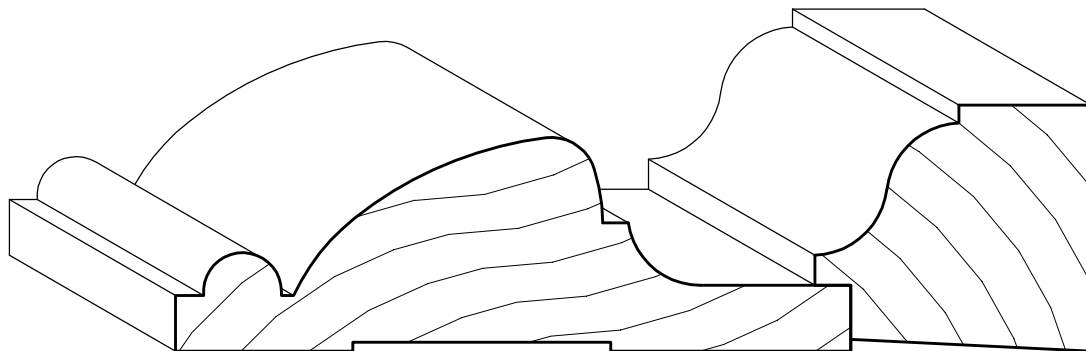

SMC-346
 $1\frac{1}{8}$ " x $3\frac{1}{2}$ " BARRUS CASING

SMC-346B
 $1\frac{1}{4}$ " x $1\frac{1}{16}$ " BARRUS BACKBAND

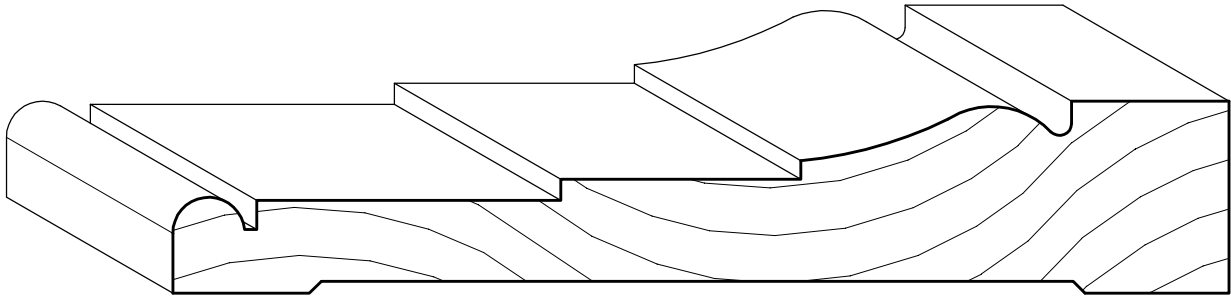

SMC-357 1" x 5 1/2" CASING

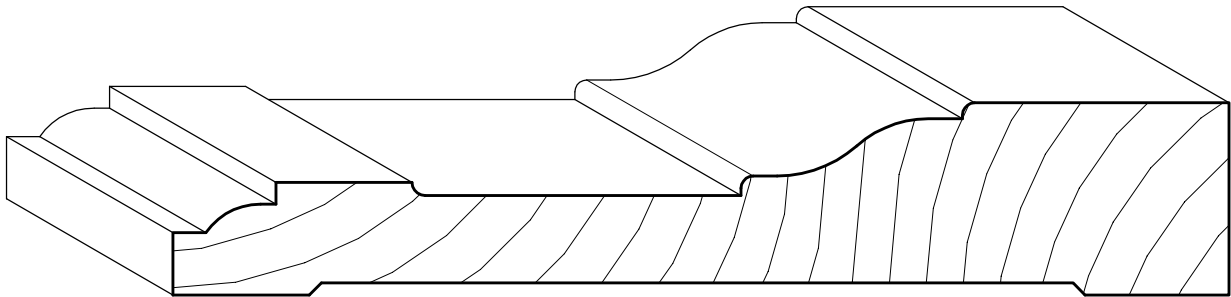

SMC-358 1" x 5 1/2" CASING

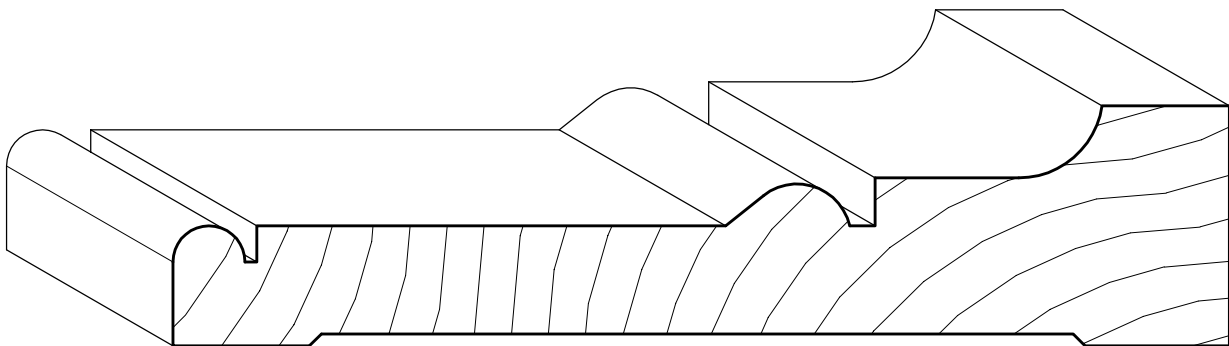

SMC-359 1 1/4" x 5 1/2" CASING

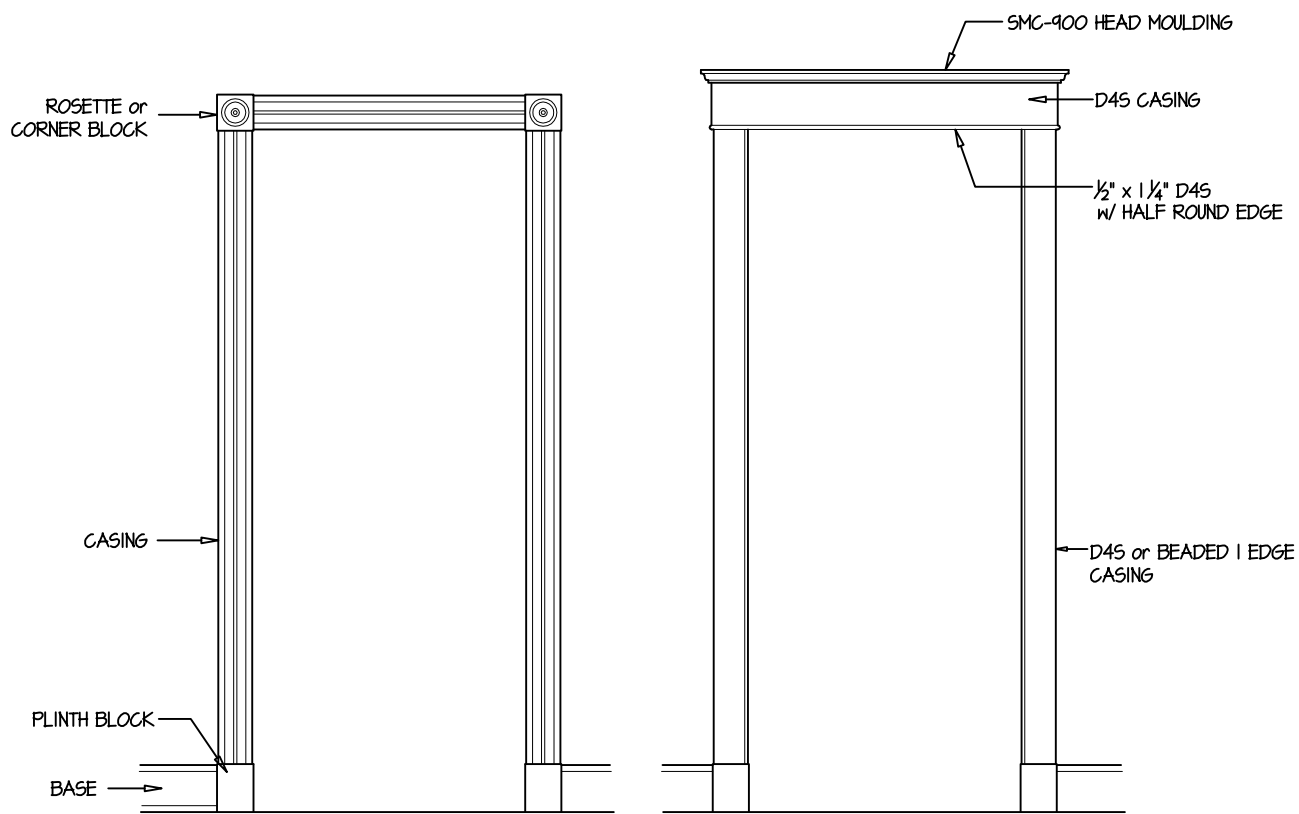

TYPICAL INTERIOR ELEVATIONS SHOWING PLINTH BLOCKS & ROSETTES

THESE ELEVATIONS NOT TO SCALE

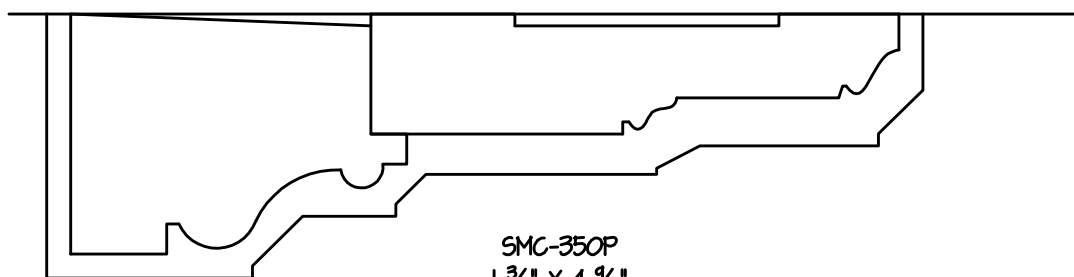

SMC-350P
1 3/8" X 4 9/16"
PLINTH BLOCK for BENTON CASING and BACKBAND (SMC-350, SMC-020)

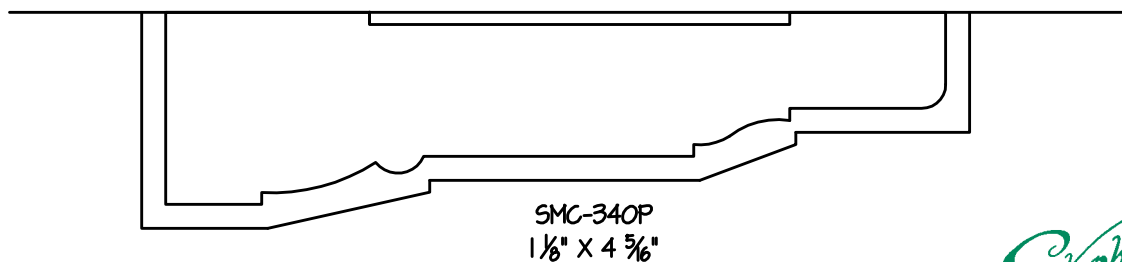

SMC-340P
1 1/8" X 4 5/16"

FULL SIZE



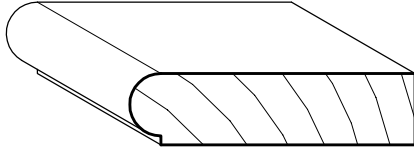

SMC-085
1/2" x 2" BEADED STOP

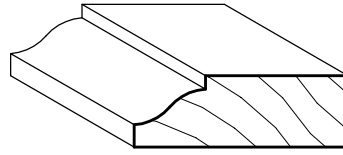

SMC-075
1/2" x 1 1/2" OG STOP

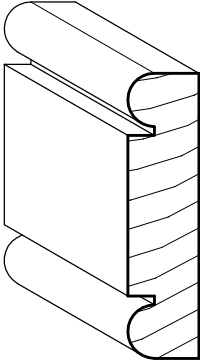

SMC-470 BEADED MULL TRIM

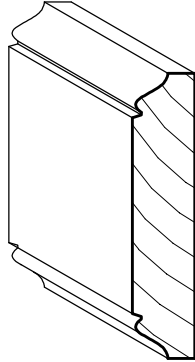

SMC-460 BENTON MULL TRIM

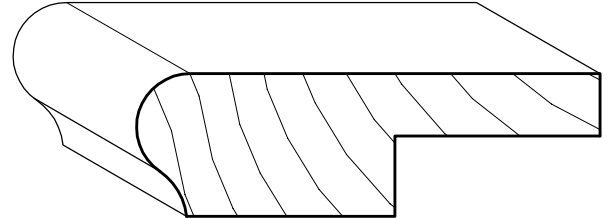

SMC-540 FLAT RABBET

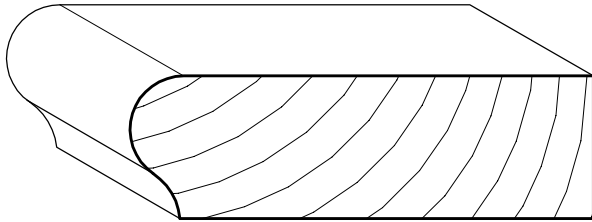

SMC-520 WINDOW STOOL (NO RABBET)

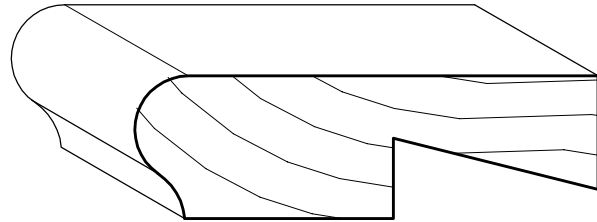

SMC-530 BEVEL RABBET

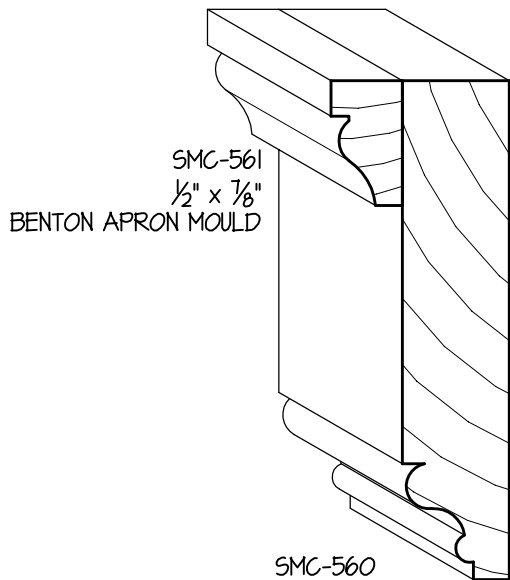

SMC-561
1/2" x 7/8"
BENTON APRON MOULD

SMC-560
3/4" x 3 1/2" BENTON APRON

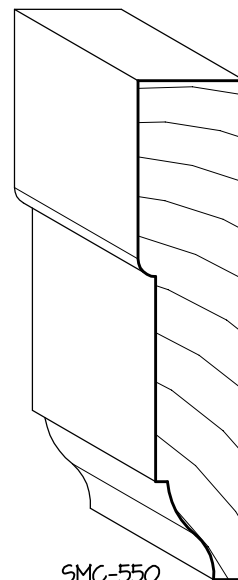

SMC-550
3/4" x 3 1/2" APRON

- SMC-530 1" x 2 3/4" (BEVEL RABBET)
- SMC-531 1" x 3 3/4" (BEVEL RABBET)
- SMC-532 1" x 5 1/2" (BEVEL RABBET)
- SMC-533 1" x 7 1/2" (BEVEL RABBET)

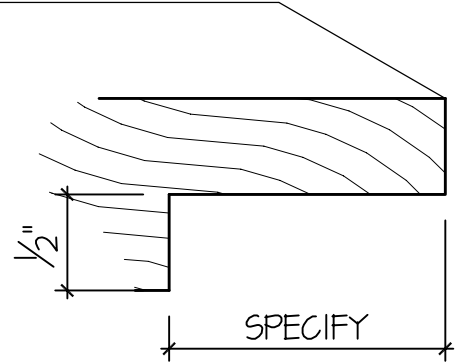
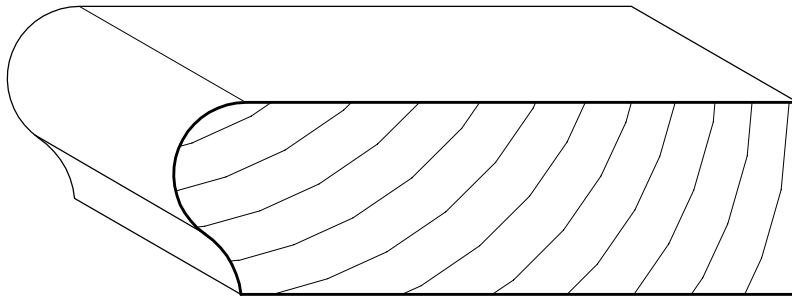
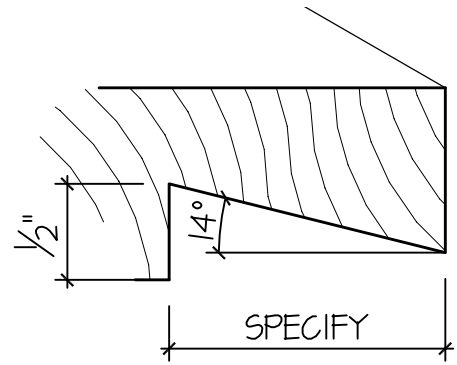

- SMC-520 1" x 2 3/4" (NO RABBET)
- SMC-521 1" x 3 3/4" (NO RABBET)
- SMC-522 1" x 5 1/2" (NO RABBET)
- SMC-523 1" x 7 1/2" (NO RABBET)

- SMC-540 1" x 2 3/4" (FLAT RABBET)
- SMC-541 1" x 3 3/4" (FLAT RABBET)
- SMC-542 1" x 5 1/2" (FLAT RABBET)
- SMC-543 1" x 7 1/2" (FLAT RABBET)

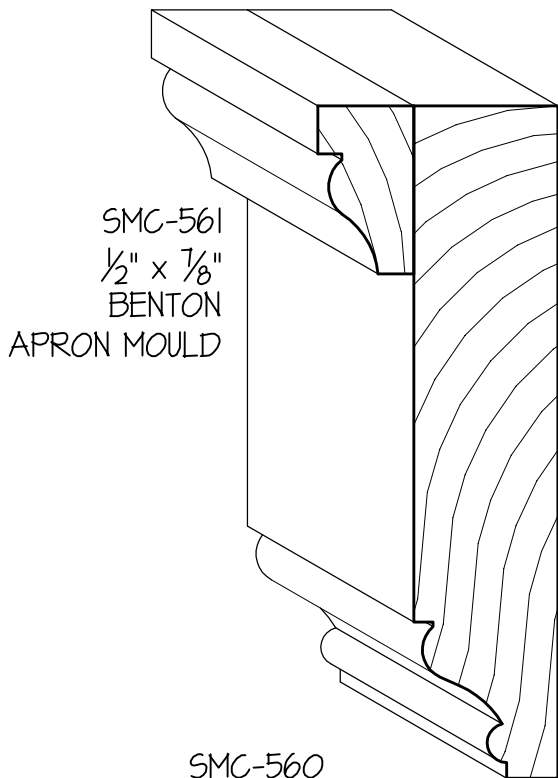

SMC-561
1/2" x 7/8"
BENTON
APRON MOULD

SMC-560
3/4" x 3 1/2" BENTON APRON

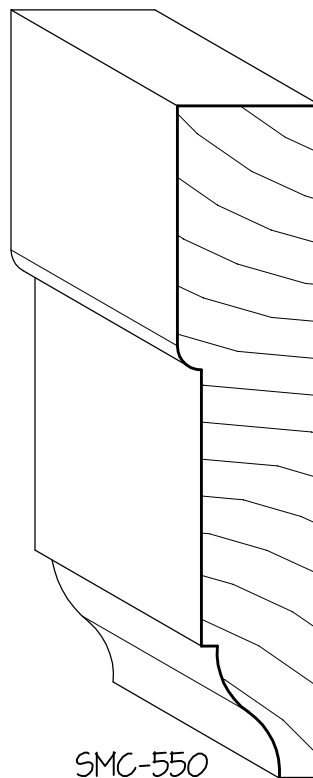

SMC-550
3/4" x 3 1/2" APRON

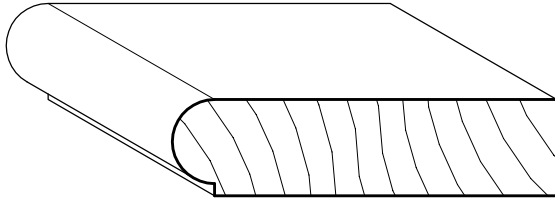

BEADED STOP

- SMC-080 1/2" x 3/4"
- SMC-081 1/2" x 1"
- SMC-082 1/2" x 1 1/4"
- SMC-083 1/2" x 1 1/2"
- SMC-084 1/2" x 1 3/4"
- SMC-085 1/2" x 2"
- SMC-086 1/2" x 2 1/4"

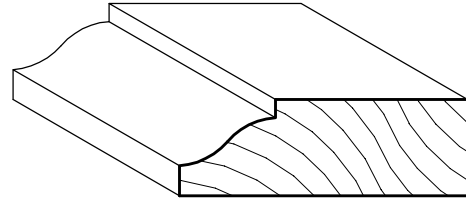

SMC-075

1/2" x 1 1/2" OG STOP

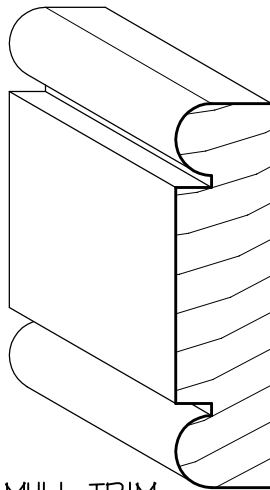

BEADED MULL TRIM

- SMC-470 1/2" x 1 1/4"
- SMC-471 1/2" x 1 1/2"
- SMC-472 1/2" x 2"
- SMC-473 1/2" x 3 1/2"

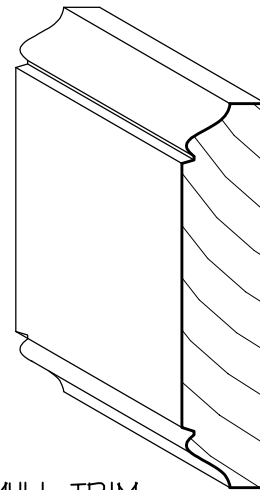

BENTON MULL TRIM

- SMC-460 1/2" x 1 1/4"
- SMC-461 1/2" x 1 1/2"
- SMC-462 1/2" x 2"
- SMC-463 1/2" x 3 1/2"



SMC-101
 $\frac{3}{4}$ " x $1\frac{3}{4}$ "
 BED MOULD

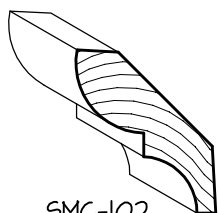

SMC-102
 $\frac{3}{4}$ " x $2\frac{3}{4}$ "
 BED MOULD

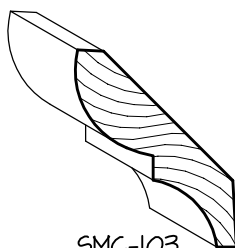

SMC-103
 $\frac{3}{4}$ " x $3\frac{1}{4}$ "
 BED MOULD

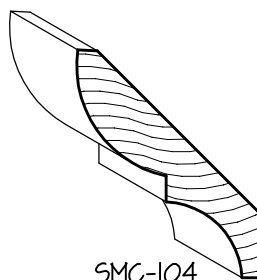

SMC-104
 $\frac{3}{4}$ " x $3\frac{3}{4}$ "
 BED MOULD

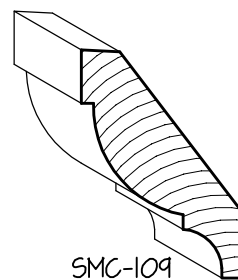

SMC-109
 1 " x $3\frac{5}{8}$ "
 BED MOULD w/ LEG

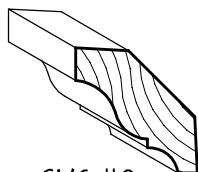

SMC-110
 $\frac{3}{4}$ " x $2\frac{1}{4}$ " CROWN

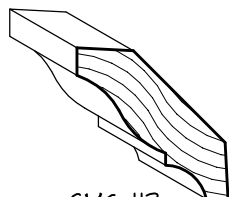

SMC-113
 $\frac{3}{4}$ " x $2\frac{3}{4}$ " CROWN

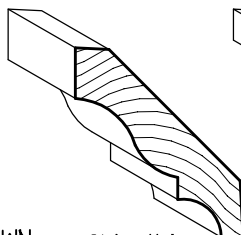

SMC-114
 $\frac{3}{4}$ " x $3\frac{1}{4}$ " CROWN

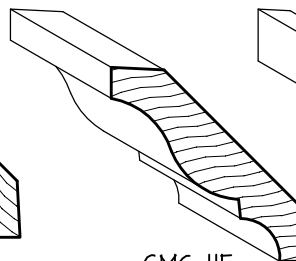

SMC-115
 $\frac{3}{4}$ " x $3\frac{1}{2}$ " CROWN

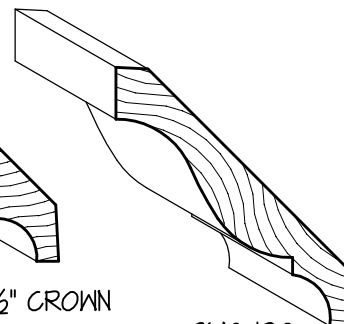

SMC-120
 $\frac{3}{4}$ " x $4\frac{1}{2}$ "
 CROWN

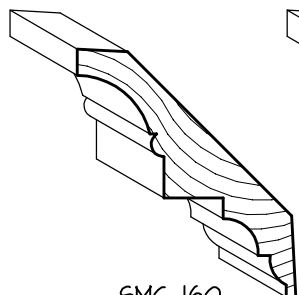

SMC-160
 $1\frac{1}{8}$ " x $4\frac{1}{4}$ "
 CURTIS CROWN

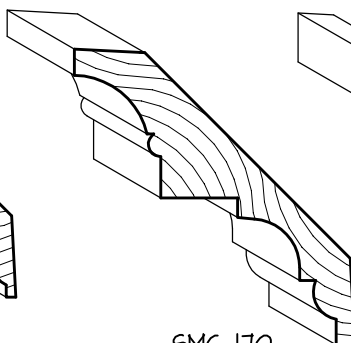

SMC-170
 $1\frac{1}{8}$ " x $5\frac{1}{4}$ "
 CURTIS CROWN

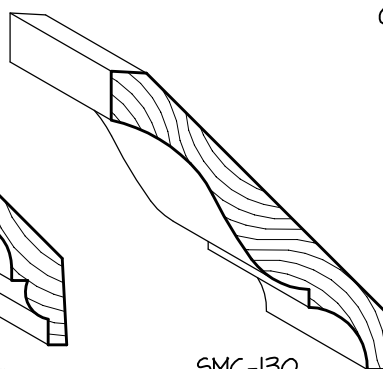

SMC-130
 $\frac{3}{4}$ " x $5\frac{1}{4}$ "
 CROWN MOULD

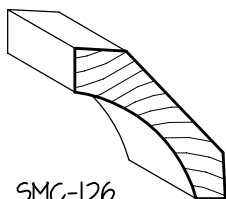

SMC-126
 $\frac{3}{4}$ " x $2\frac{3}{4}$ "
 COVE MOULD

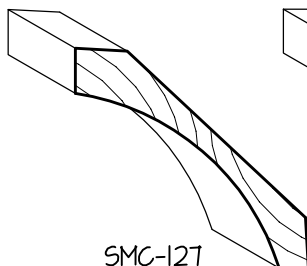

SMC-127
 $\frac{3}{4}$ " x $4\frac{1}{8}$ "
 COVE MOULD

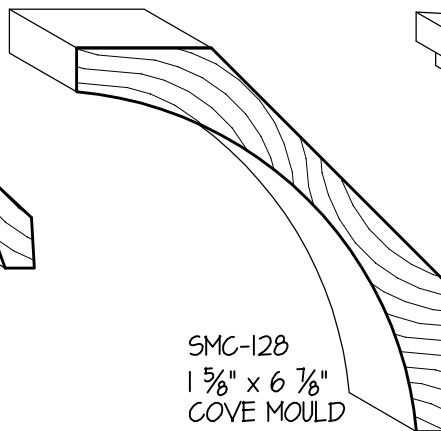

SMC-128
 $1\frac{5}{8}$ " x $6\frac{7}{8}$ "
 COVE MOULD

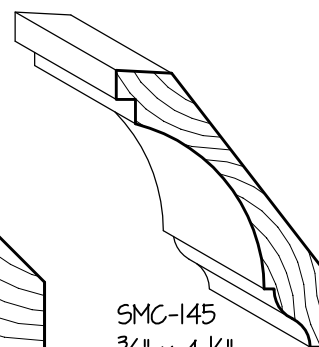

SMC-145
 $\frac{3}{4}$ " x $4\frac{1}{2}$ "
 COVE MOULD

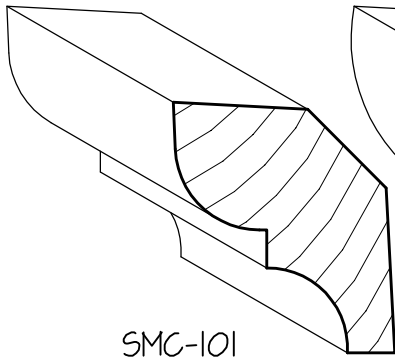

SMC-101
 $\frac{3}{4}$ " x $1\frac{3}{4}$ " BED MOULD

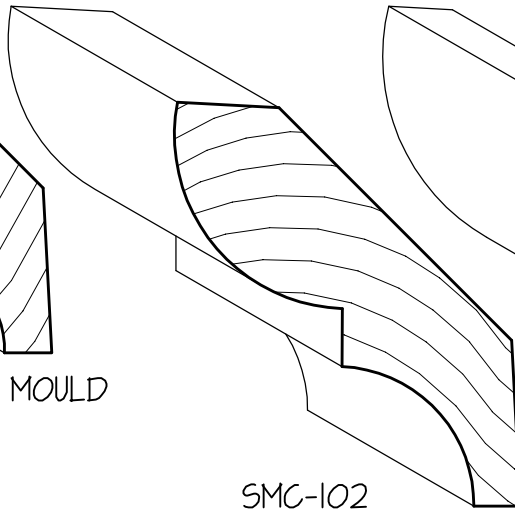

SMC-102
 $\frac{3}{4}$ " x $2\frac{3}{4}$ " BED MOULD

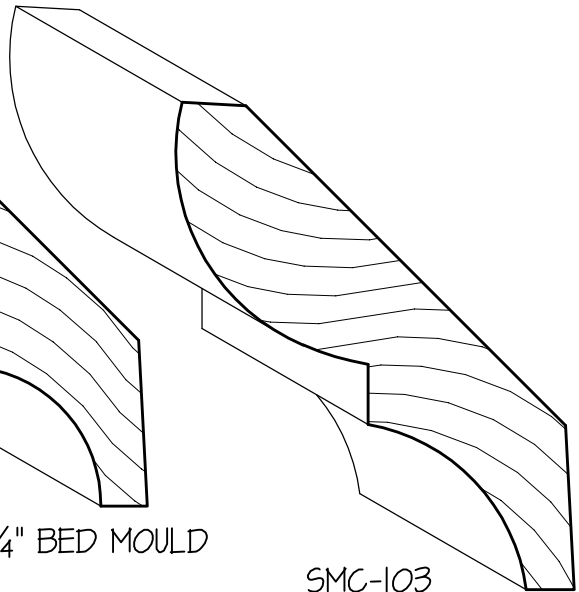

SMC-103
 $\frac{3}{4}$ " x $3\frac{1}{4}$ " BED MOULD

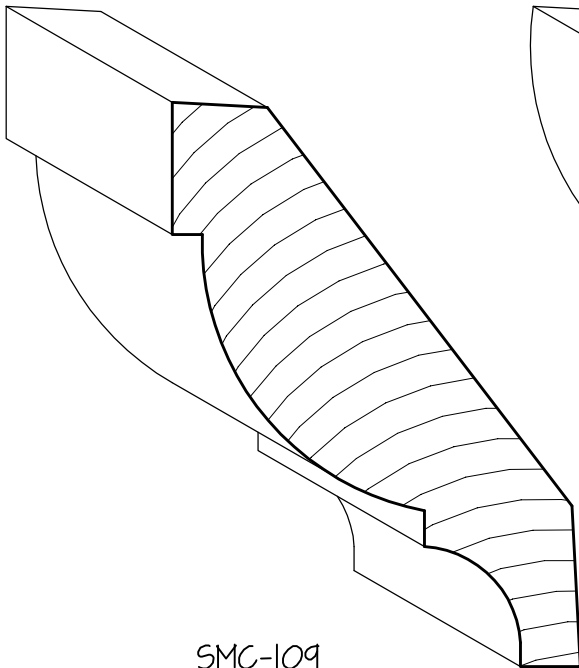

SMC-109
1" x $3\frac{5}{8}$ " BED MOULD w/ LEG

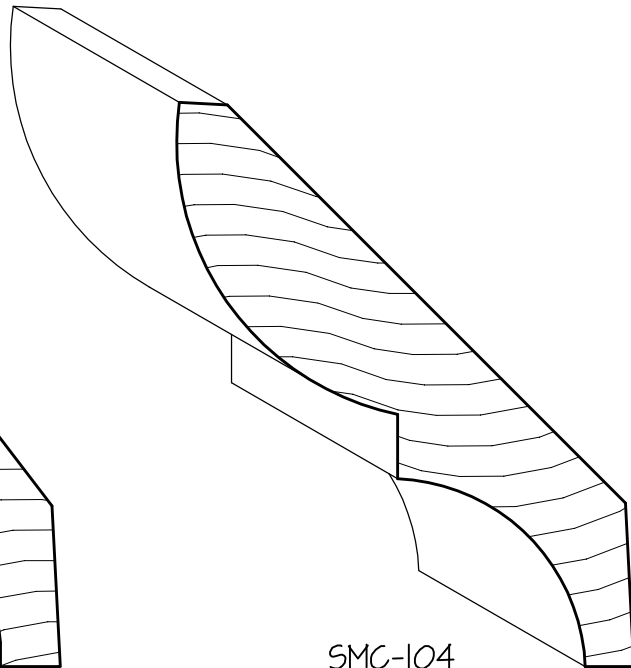

SMC-104
 $\frac{3}{4}$ " x $3\frac{3}{4}$ " BED MOULD

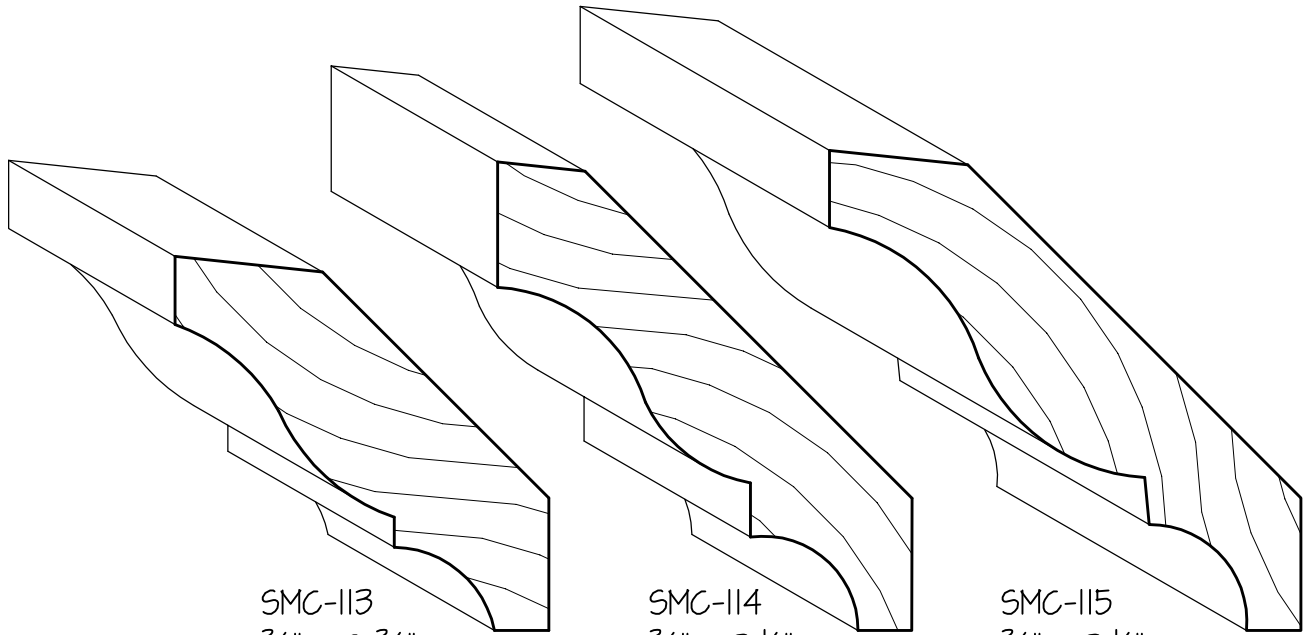

SMC-113
 $\frac{3}{4}$ " x $2\frac{3}{4}$ "
CROWN MOULD

SMC-114
 $\frac{3}{4}$ " x $3\frac{1}{4}$ "
CROWN MOULD

SMC-115
 $\frac{3}{4}$ " x $3\frac{1}{2}$ "
CROWN MOULD

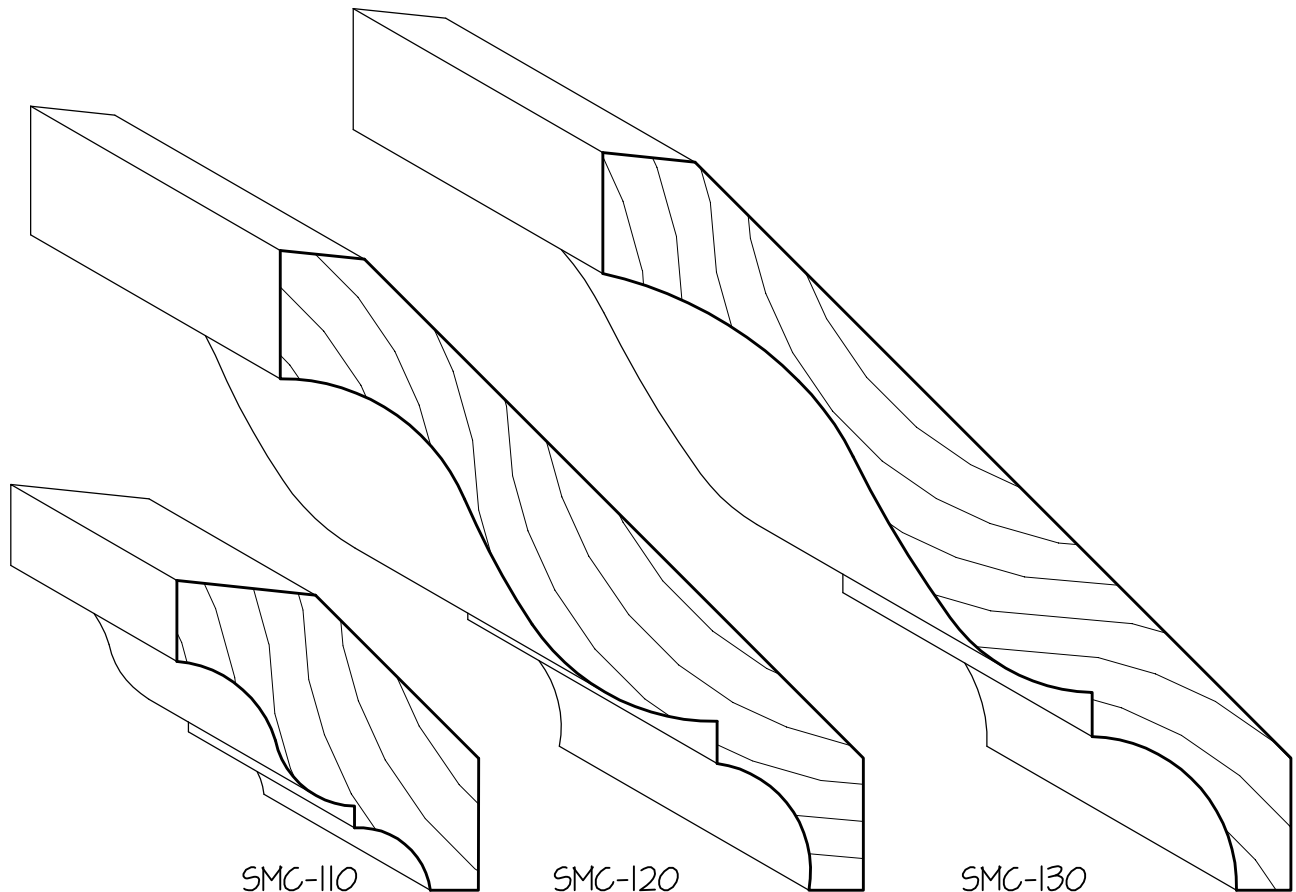

SMC-110
 $\frac{3}{4}$ " x $2\frac{1}{4}$ "
CROWN MOULD

SMC-120
 $\frac{3}{4}$ " x $4\frac{1}{2}$ "
CROWN MOULD

SMC-130
 $\frac{3}{4}$ " x $5\frac{1}{4}$ "
CROWN MOULD

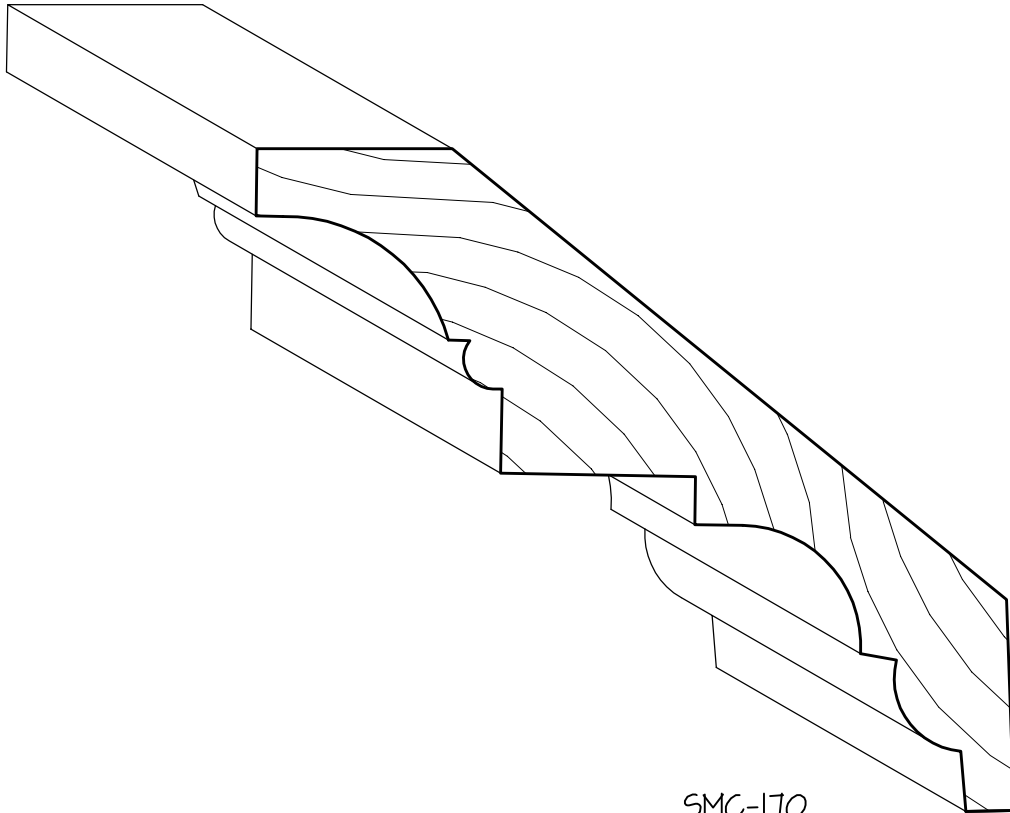

SMC-170
1 1/8" x 5 1/4" CURTIS CROWN

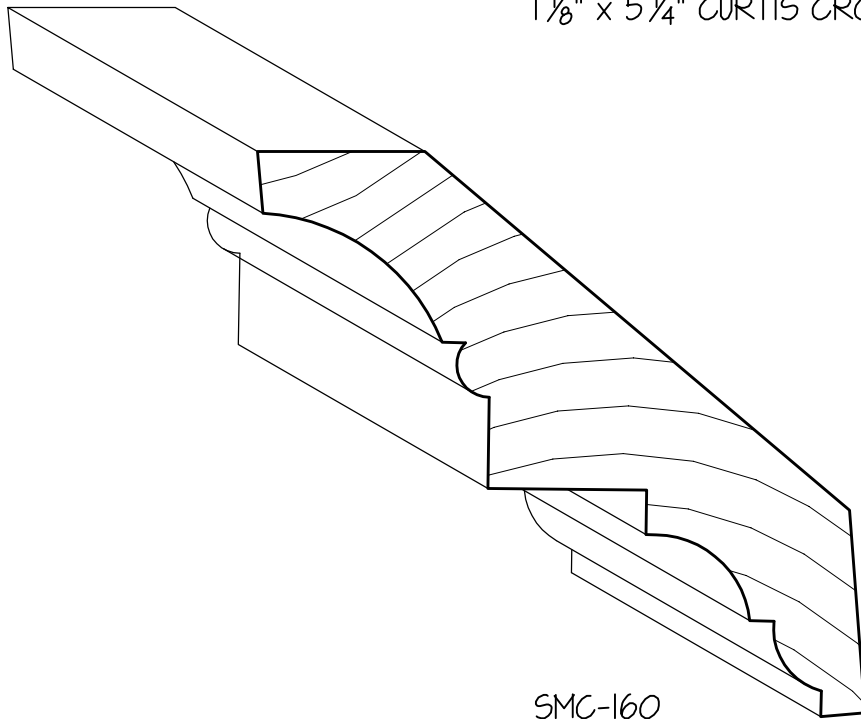

SMC-160
1 1/8" x 4 1/4" CURTIS CROWN

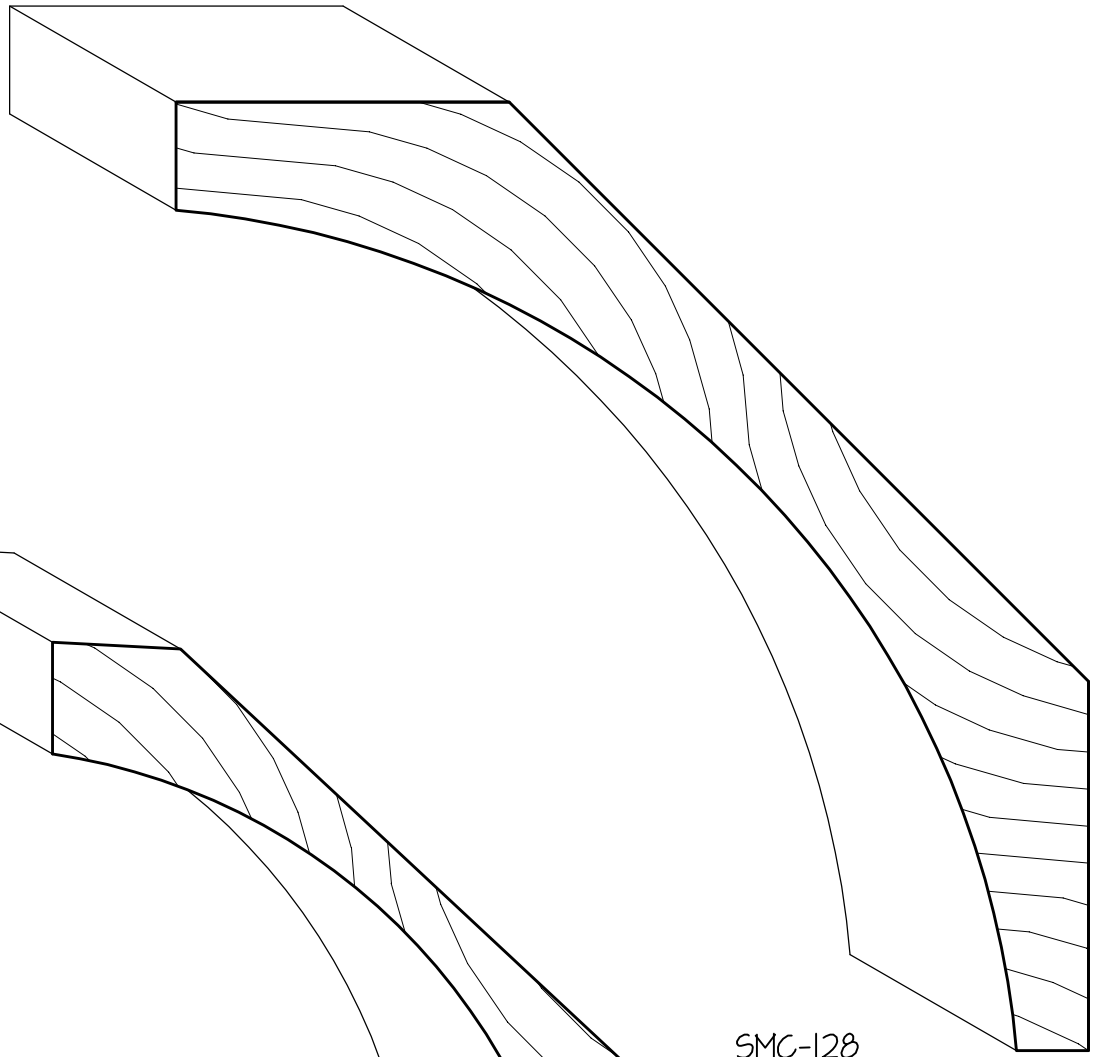

SMC-128
1 5/8" x 6 7/8" COVE MOULD

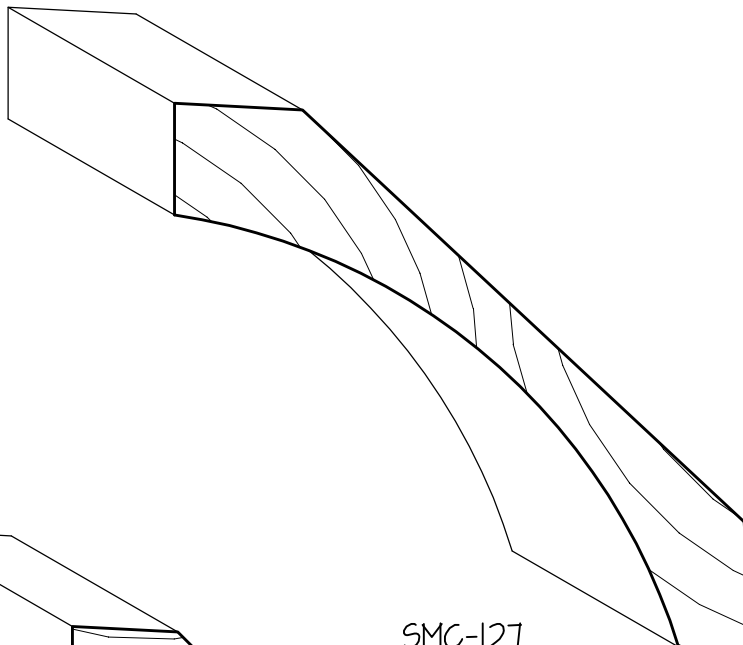

SMC-127
3/4" x 4 1/8" COVE MOULD

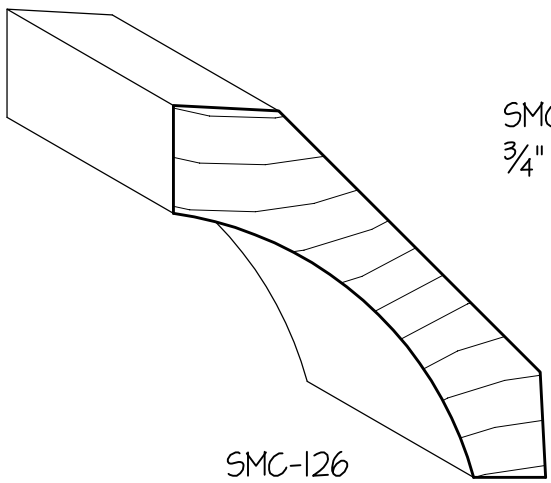

SMC-126
3/4" x 2 3/4" COVE MOULD

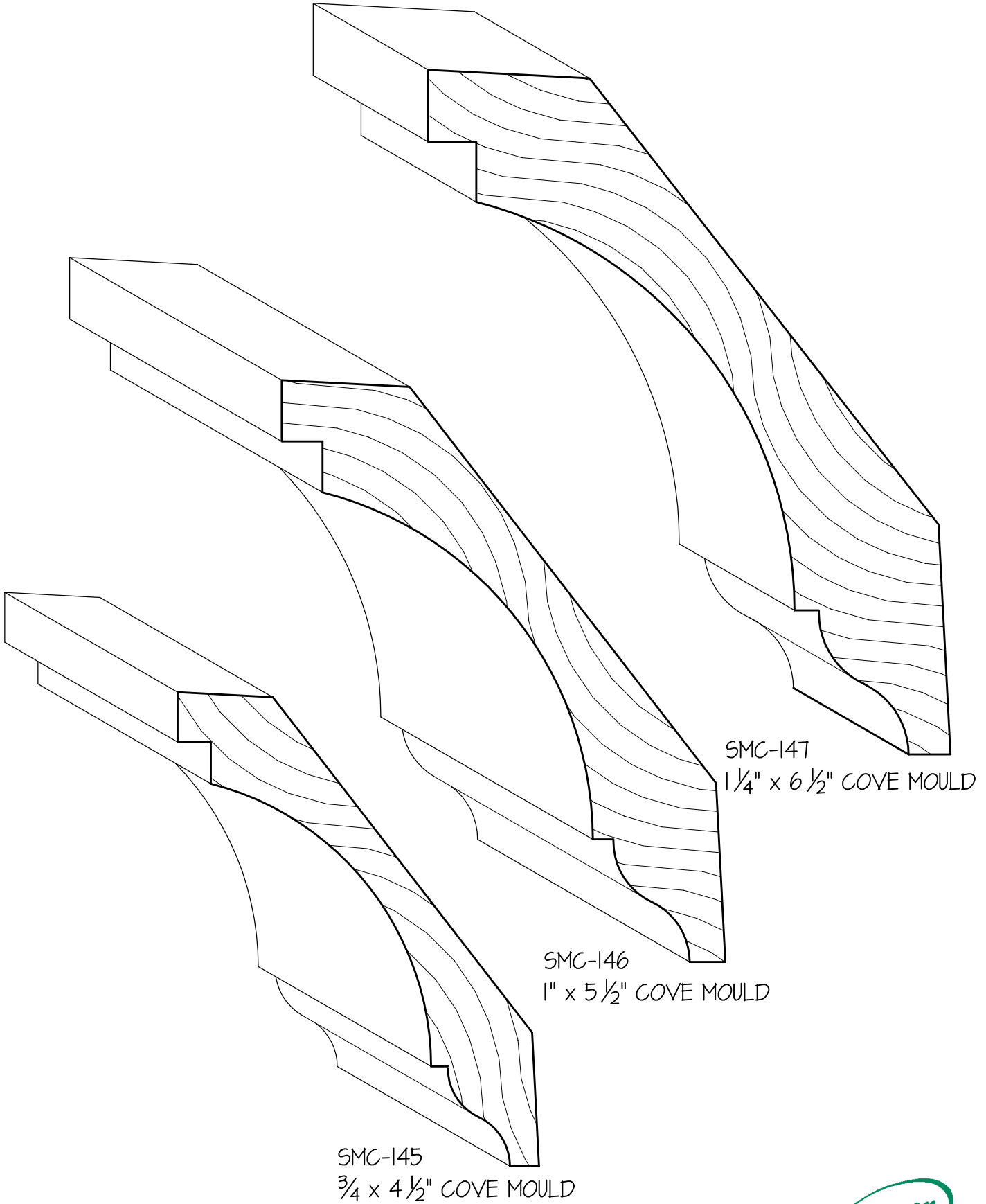

FULL SIZE

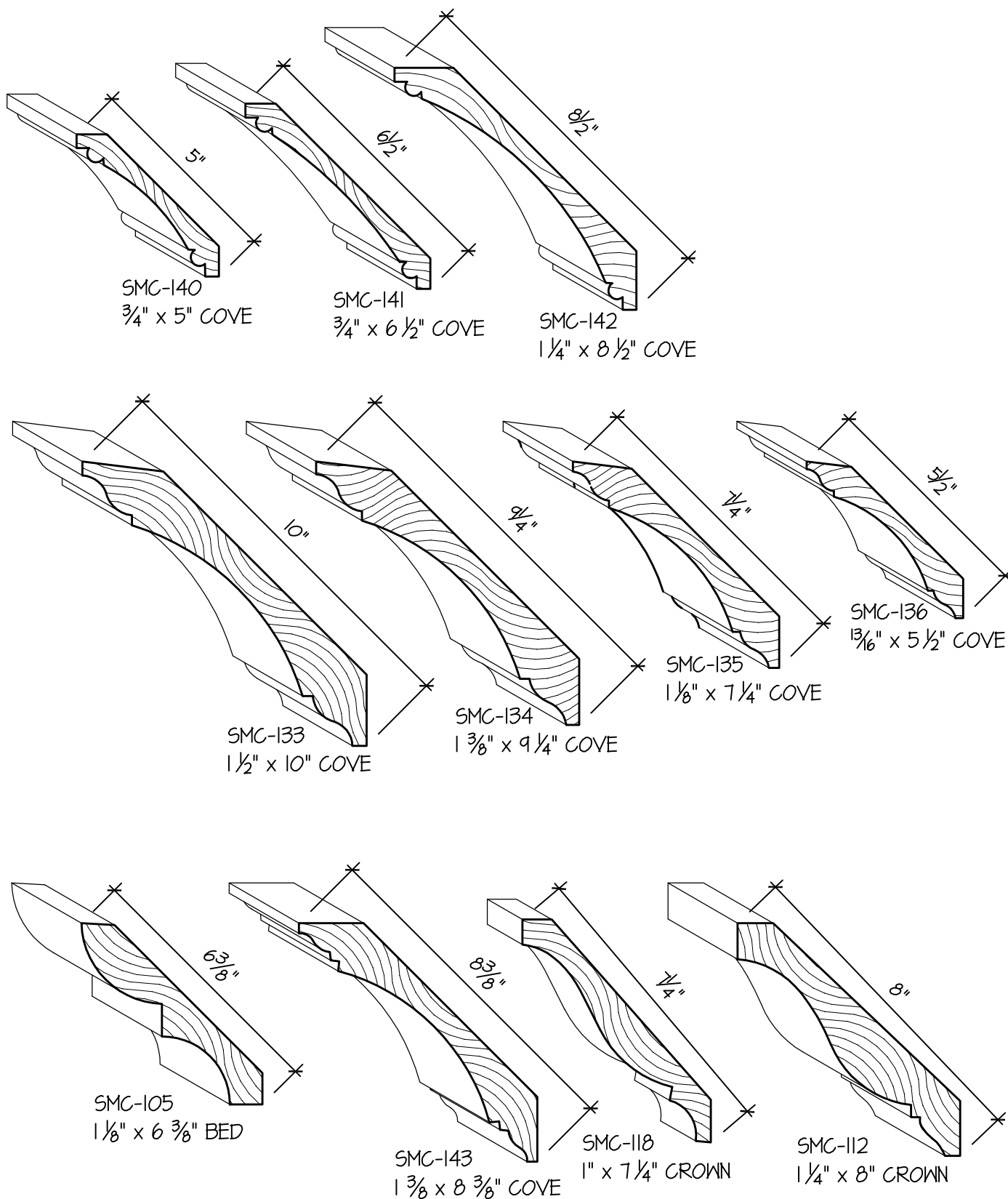

THIS PAGE NOT TO SCALE

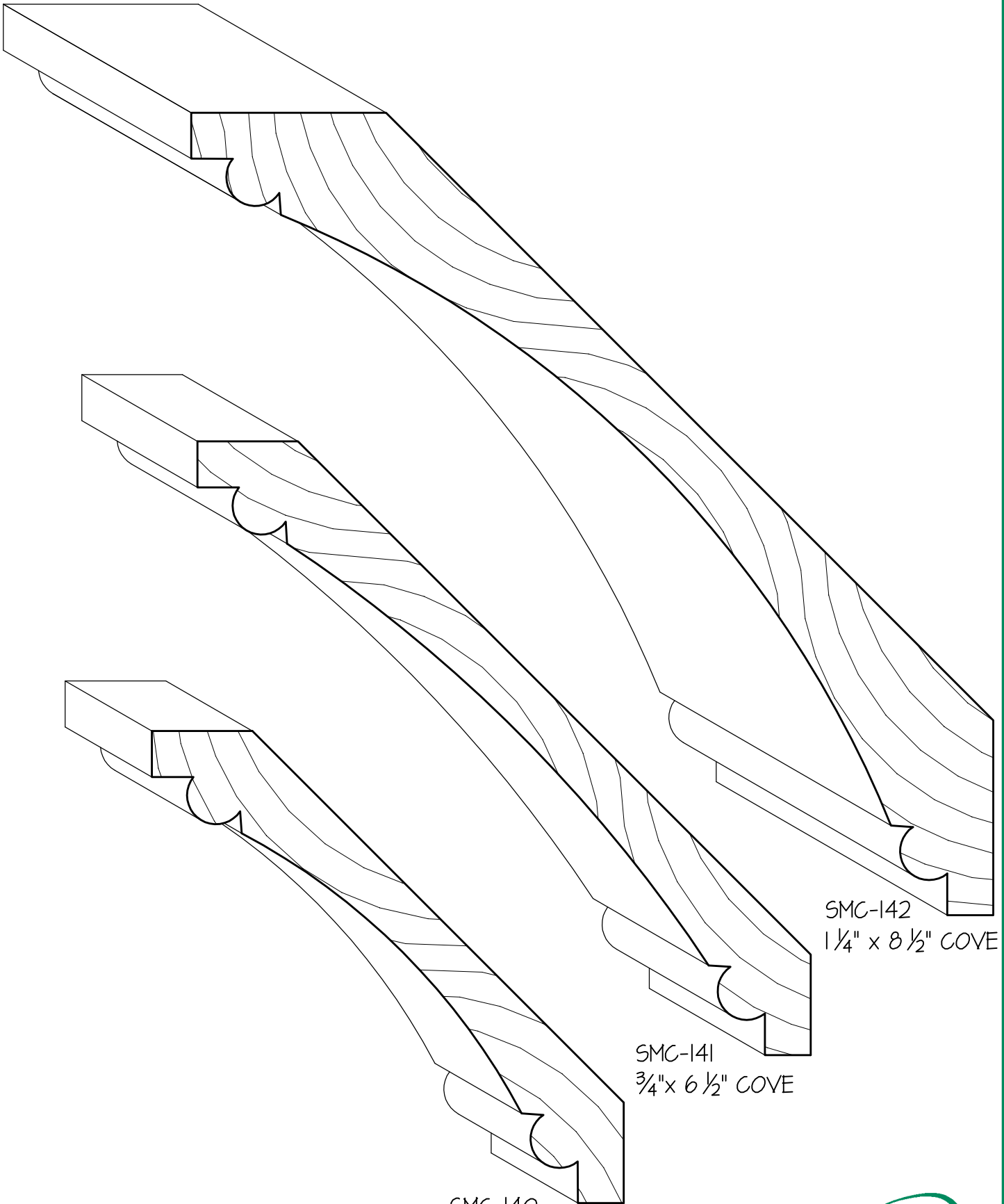

SMC-142
1 1/4" x 8 1/2" COVE

SMC-141
3/4" x 6 1/2" COVE

SMC-140
3/4" x 5" COVE

FULL SIZE

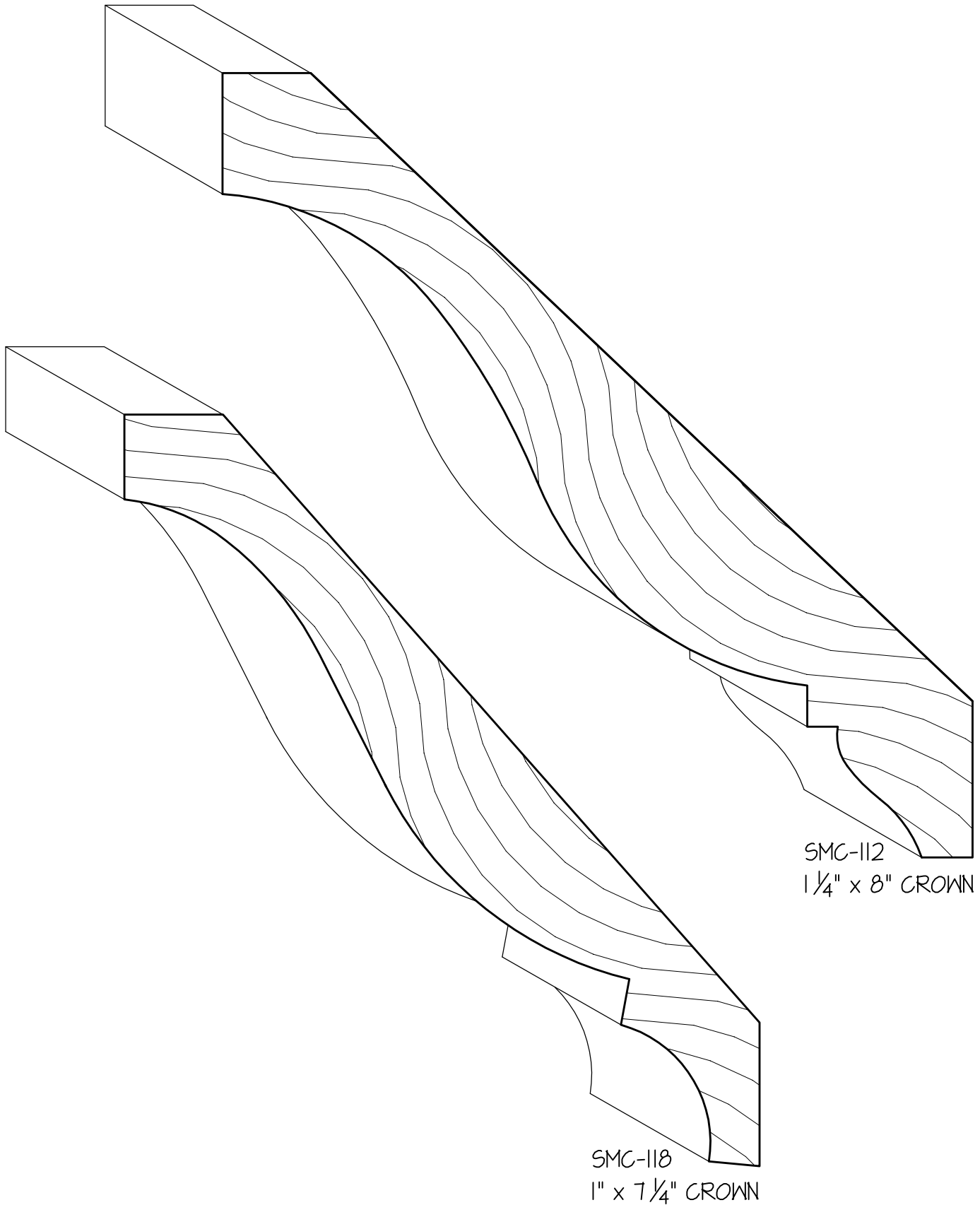

SMC-112
1/4" x 8" CROWN

SMC-118
1" x 7/4" CROWN

FULL SIZE

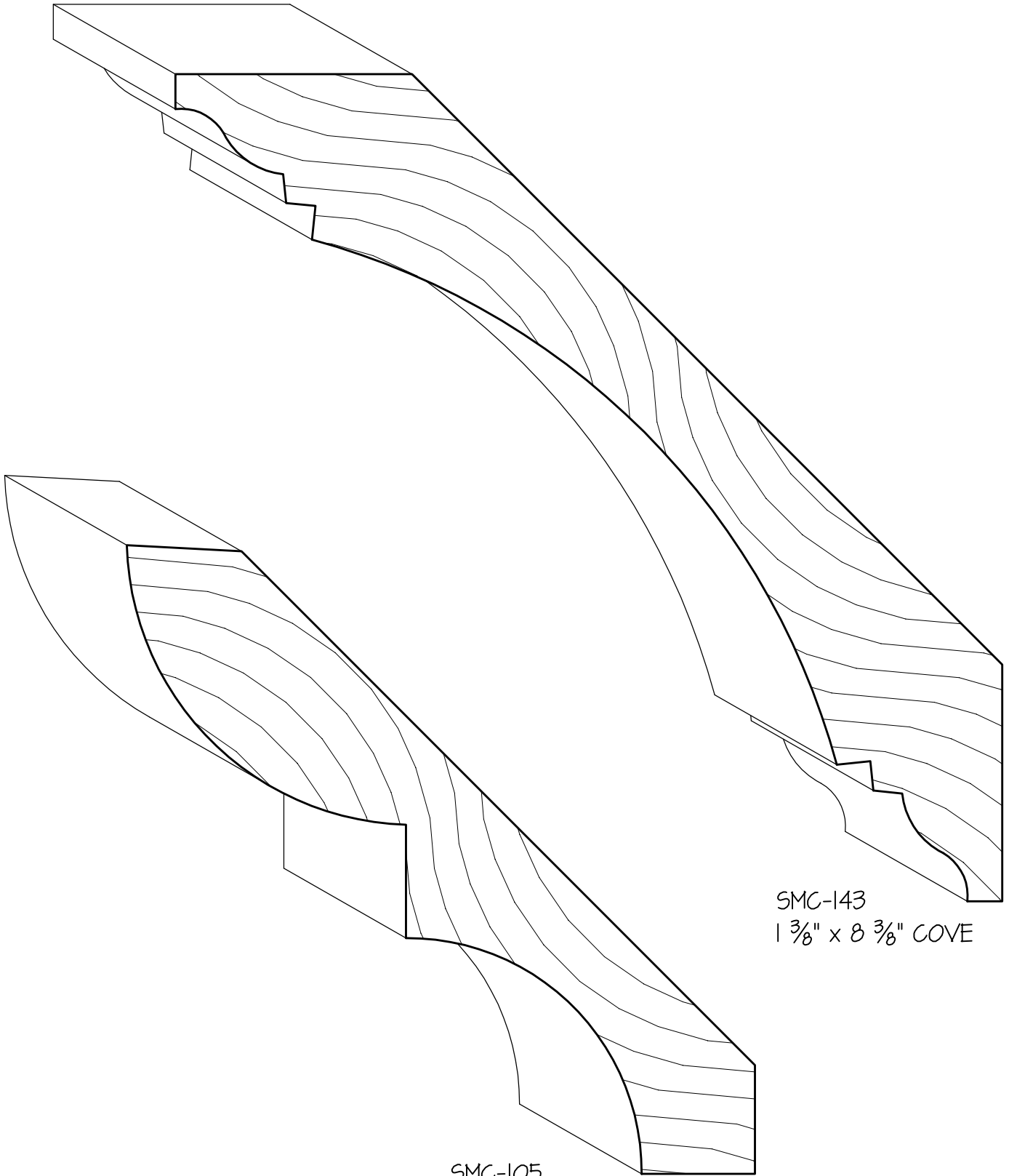

SMC-143
1 3/8" x 8 3/8" COVE

SMC-105
1 1/8" x 6 3/8" BED

FULL SIZE

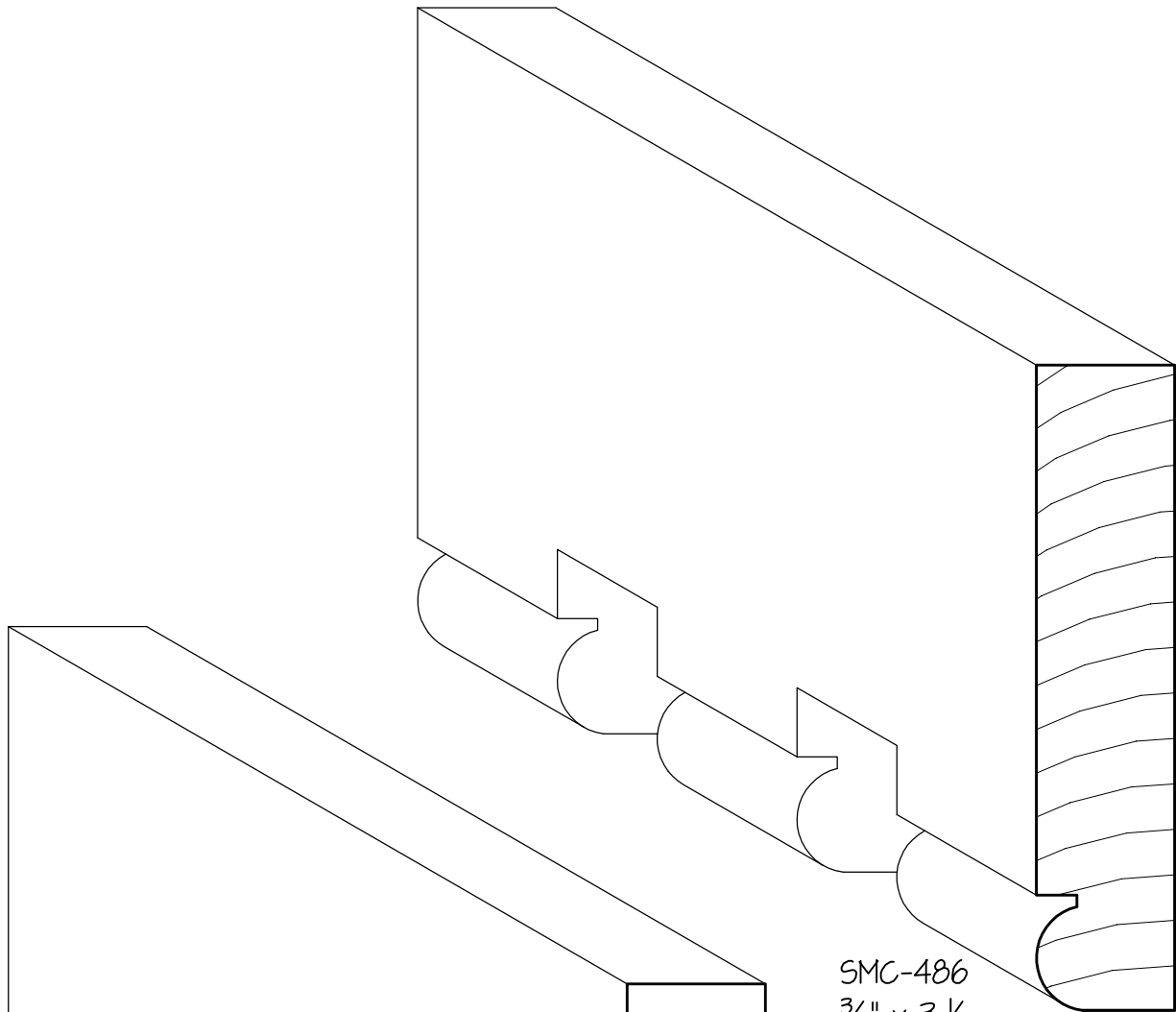

SMC-486
3/4" x 3 1/2"
BEADED DENTIL MOULD
5/8" x 1" NOTCH, 1/2" oc

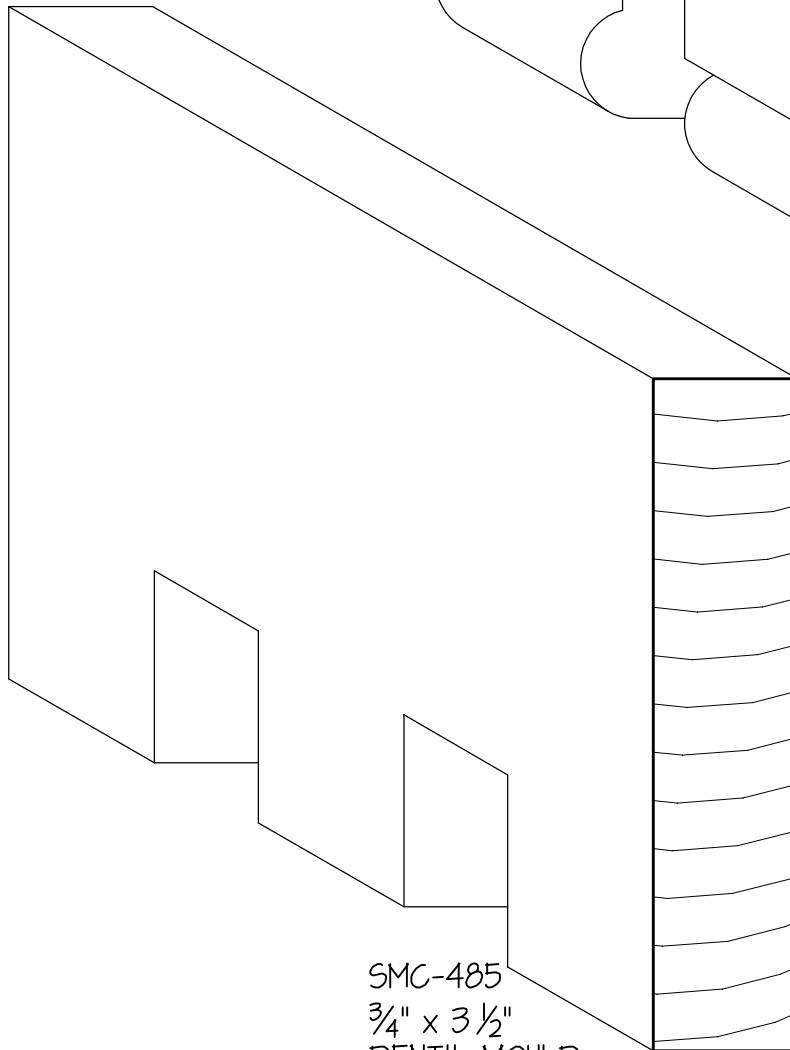

SMC-485
3/4" x 3 1/2"
DENTIL MOULD
5/8" x 1" NOTCH, 1/2" oc

FULL SIZE

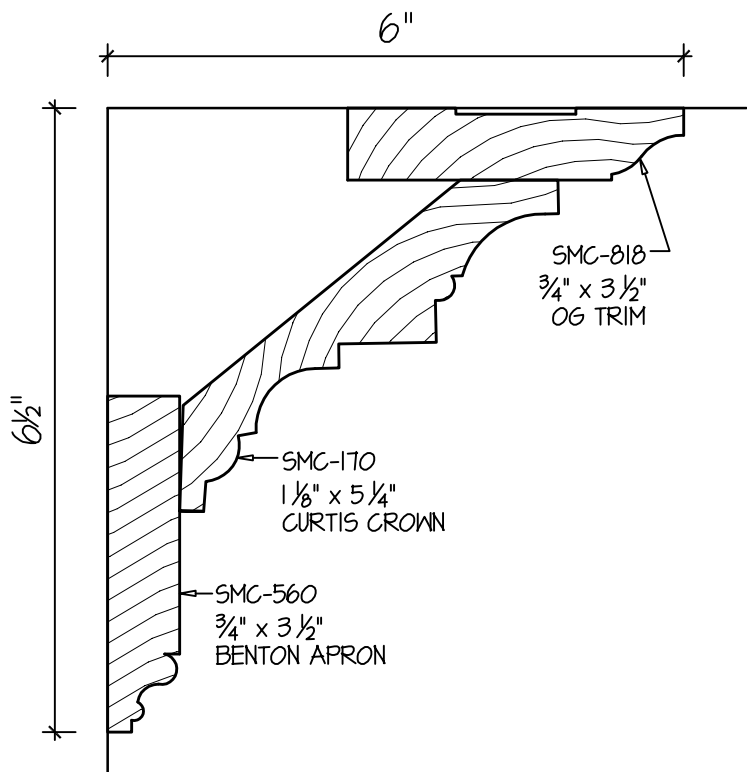
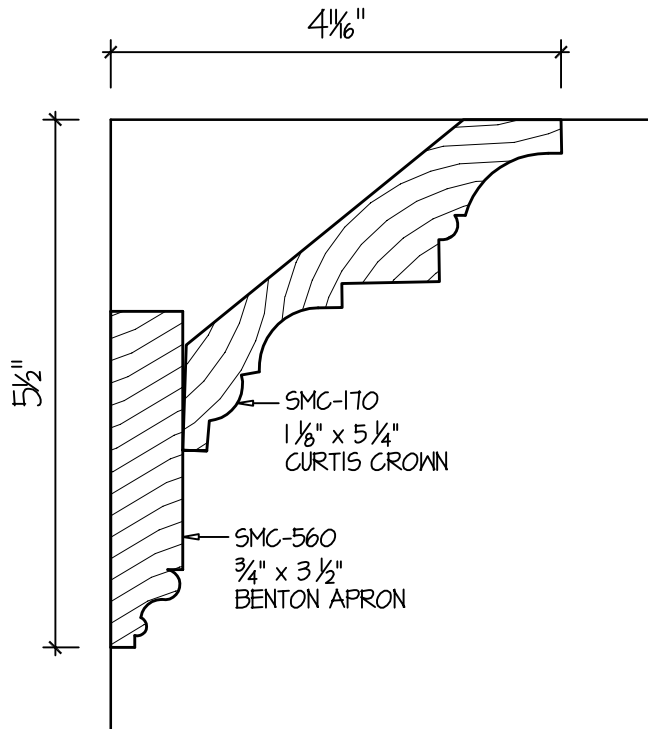

HALF SIZE

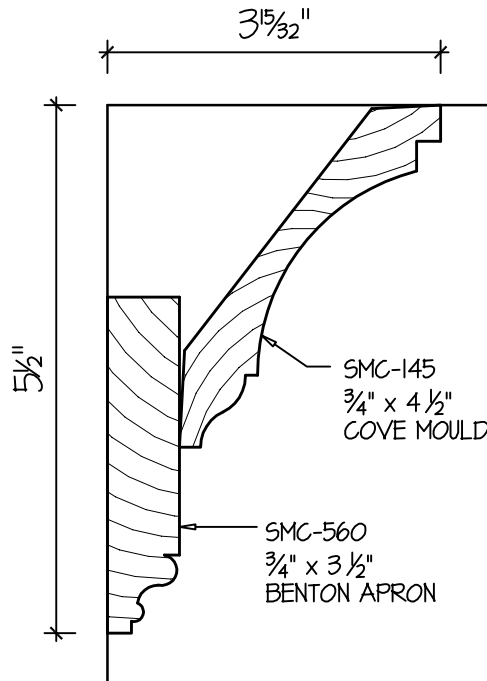
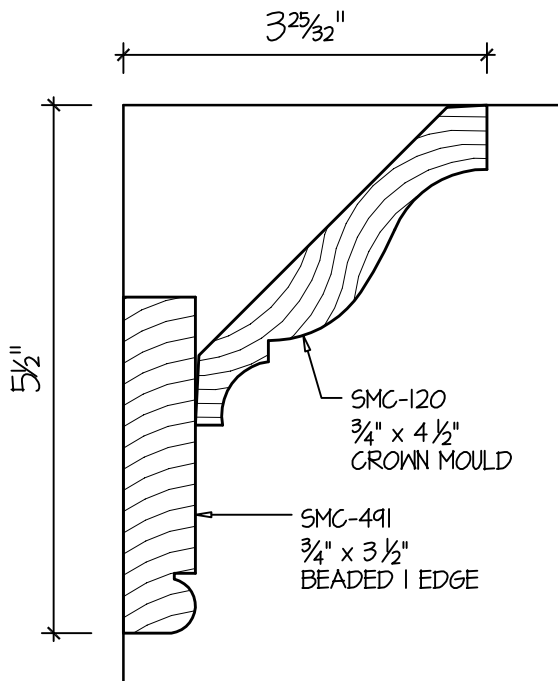

HALF SIZE

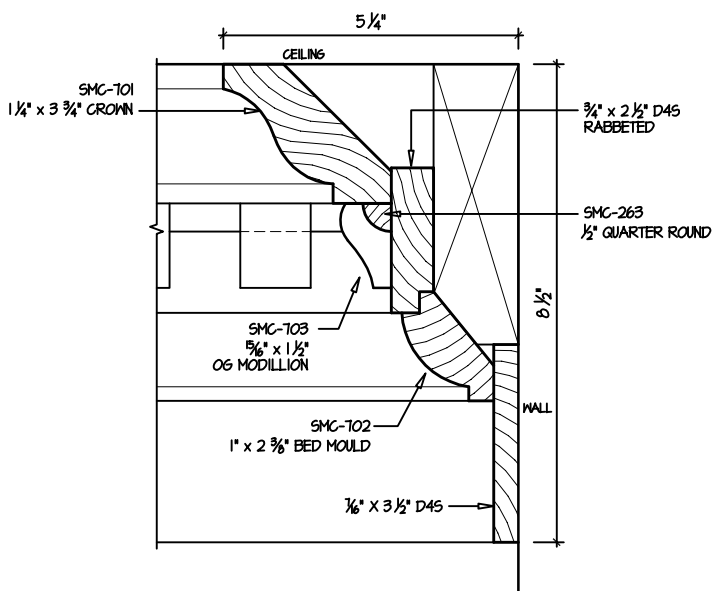
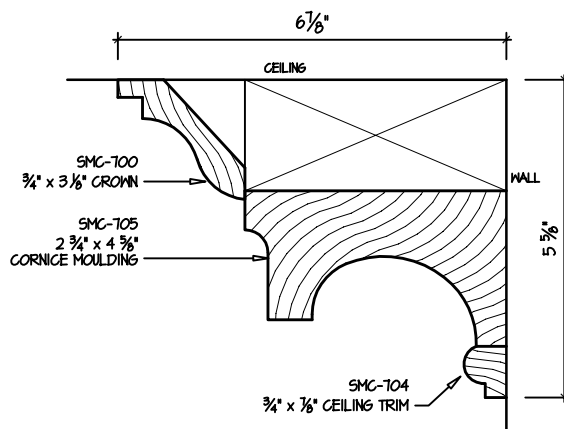
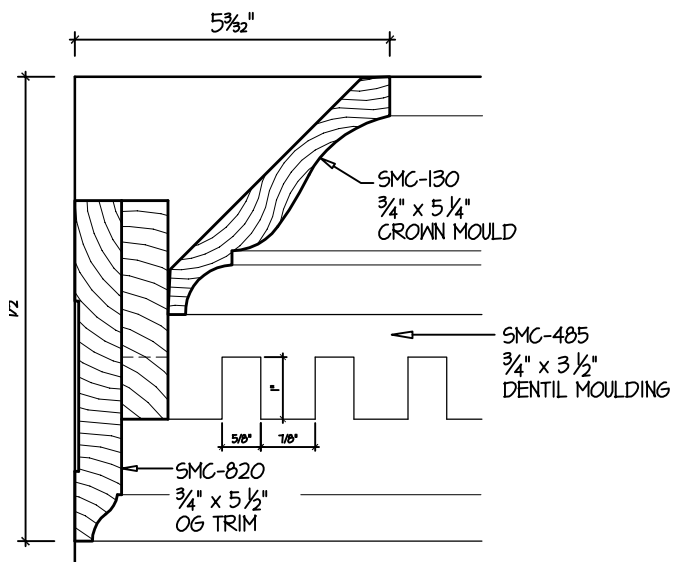
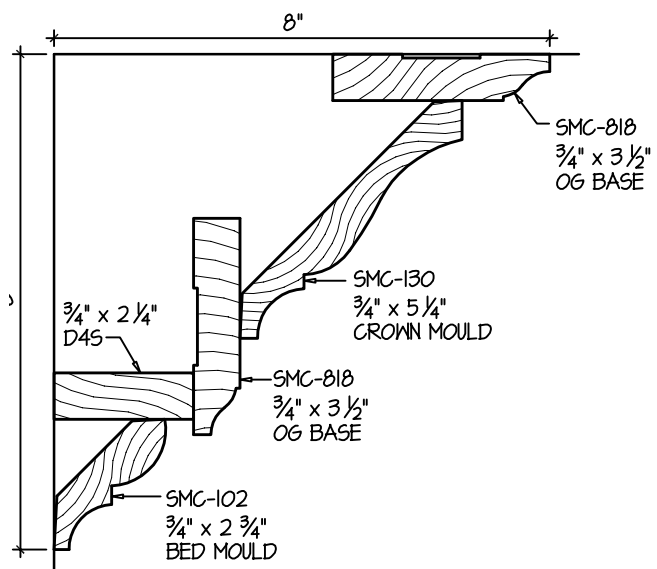

THIS PAGE NOT TO SCALE

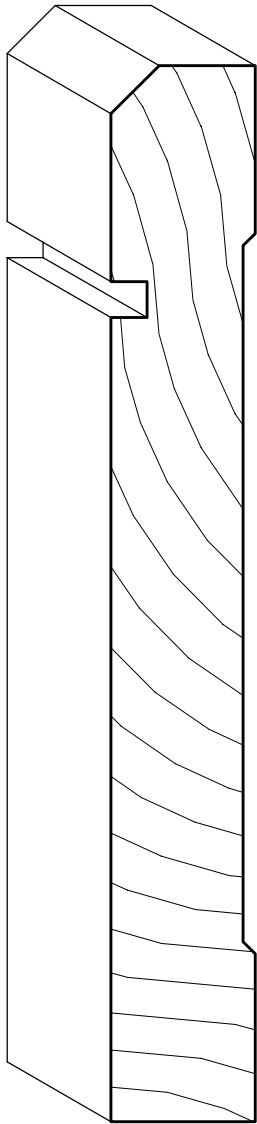

SMC-838
3/4" x 5 1/2"
BASE

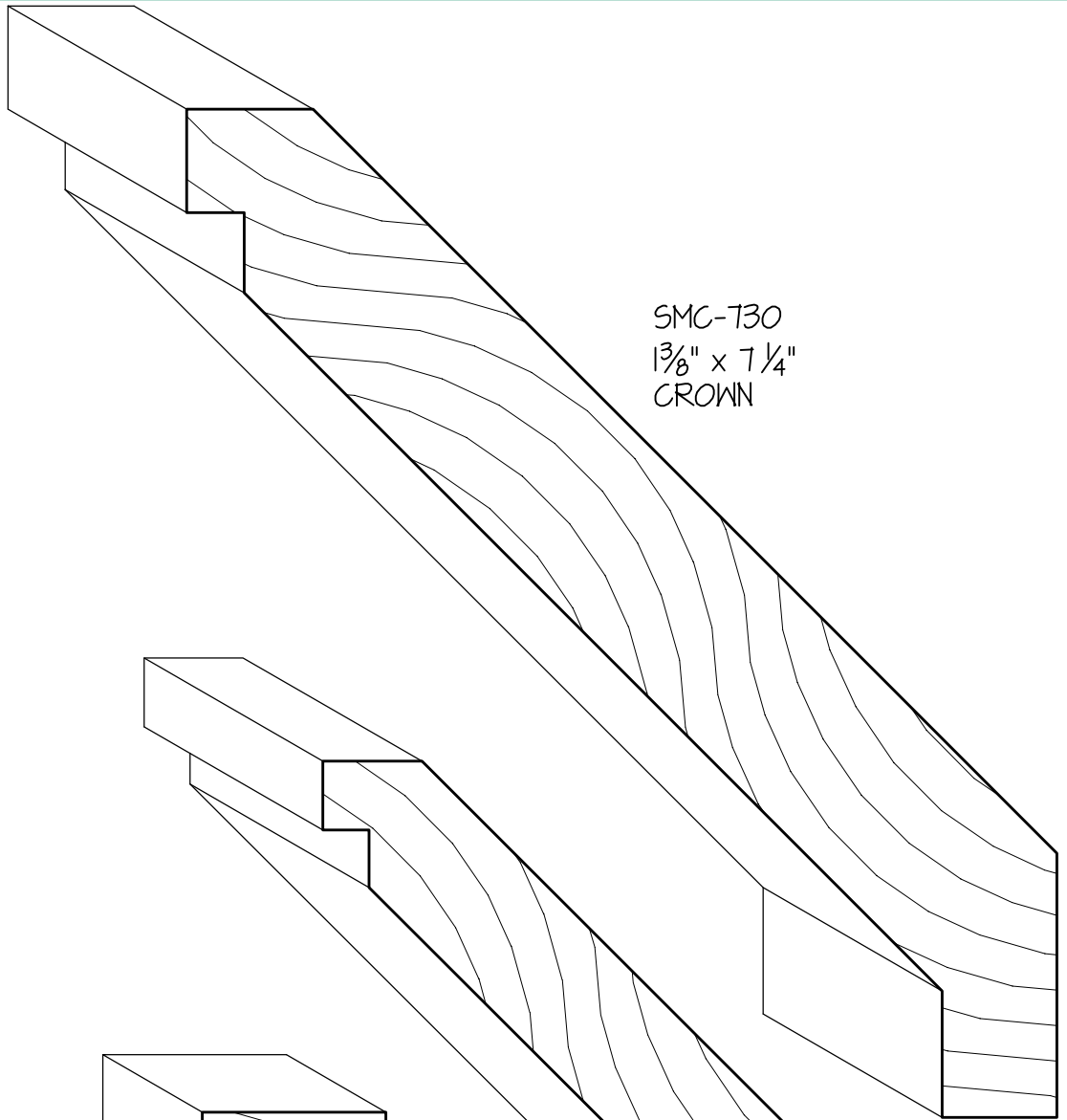

SMC-T30
1 3/8" x 7 1/4"
CROWN

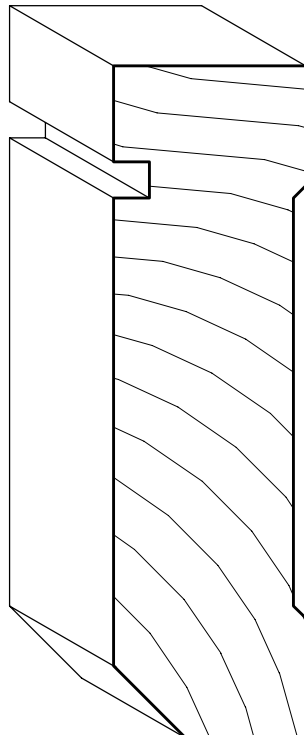

SMC-390
1" x 3 1/2"
CASING

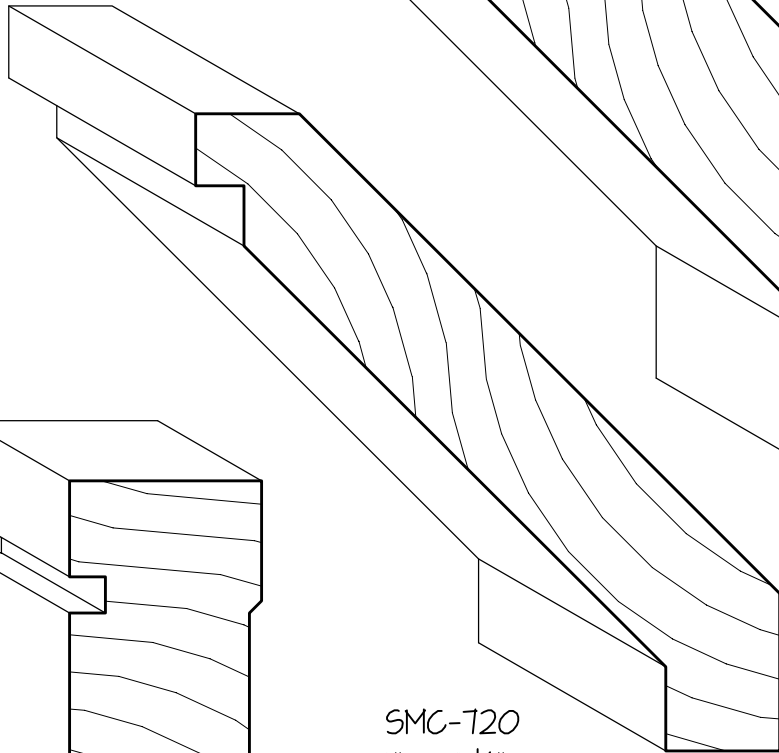

SMC-T20
1" x 4 1/2"
CROWN

FULL SIZE

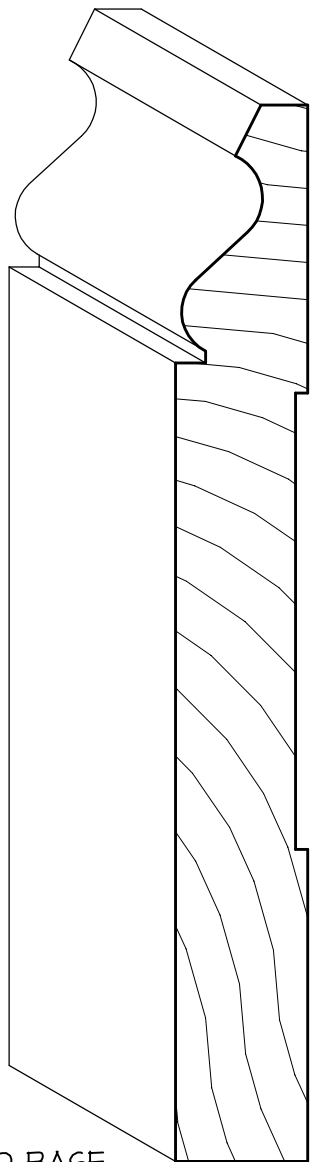

SPEED BASE
 SMC-650 $\frac{1}{16}$ " x $5\frac{1}{2}$ "
 SMC-651 $\frac{1}{16}$ " x $7\frac{1}{4}$ "

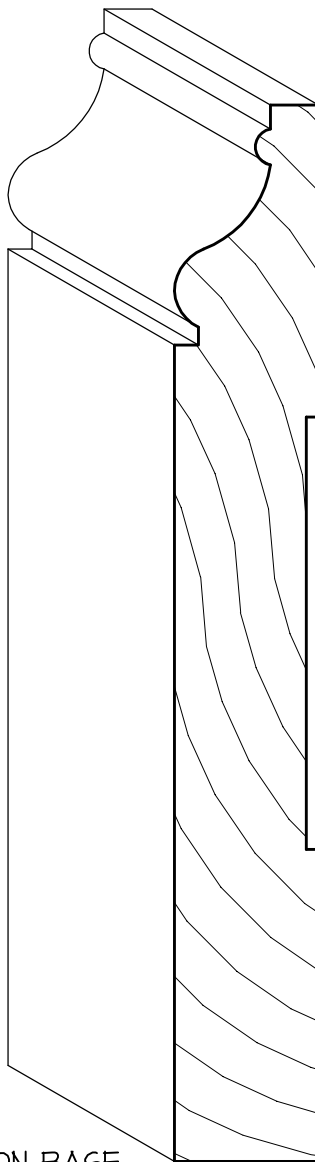

BENTON BASE
 SMC-830 $\frac{3}{4}$ " x $5\frac{1}{2}$ "
 SMC-831 $\frac{3}{4}$ " x $7\frac{1}{4}$ "

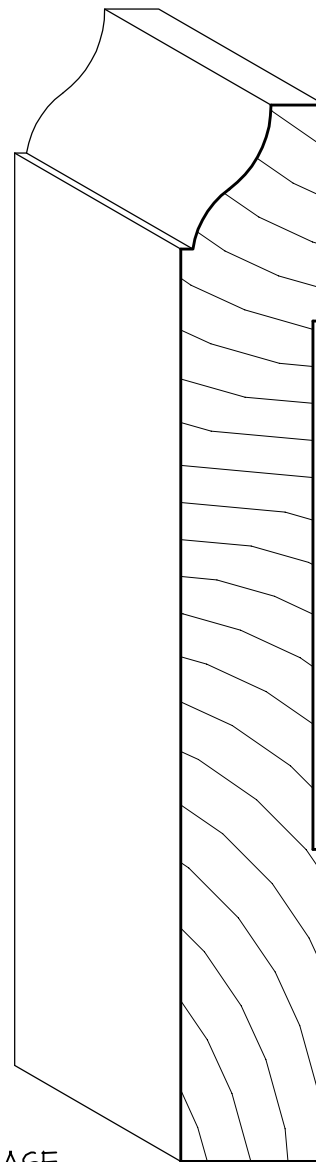

OG BASE
 SMC-818 $\frac{3}{4}$ " x $3\frac{1}{2}$ "
 SMC-819 $\frac{3}{4}$ " x $4\frac{1}{2}$ "
 SMC-820 $\frac{3}{4}$ " x $5\frac{1}{2}$ "
 SMC-821 $\frac{3}{4}$ " x $7\frac{1}{4}$ "

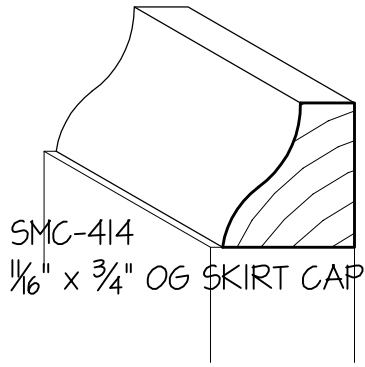

SMC-414
1/16" x 3/4" OG SKIRT CAP

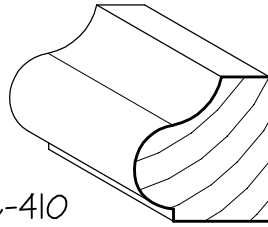

SMC-410
3/4" x 3/4" OG BASE CAP

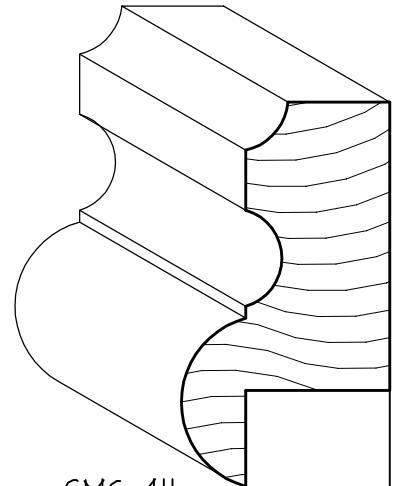

SMC-411
1/8" x 2"
RABBETED BASE CAP
USE W/ 3/4" BASEBOARD

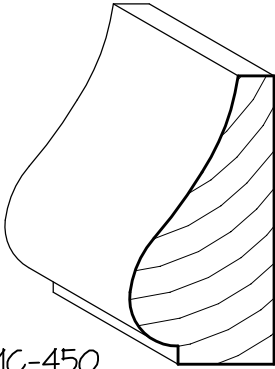

SMC-450
3/4" x 1 1/2" OG BASE CAP

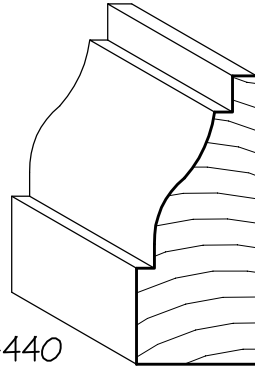

SMC-440
5/8" x 1 1/2" HERMAN BASE CAP

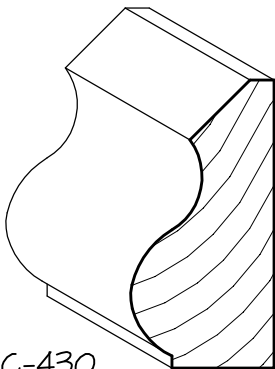

SMC-430
3/4" x 1 1/2" BEVEL BASE CAP

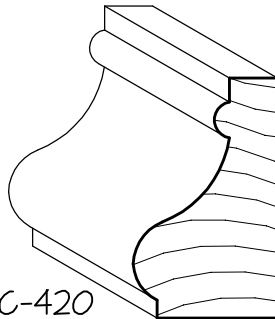

SMC-420
3/4" x 1/4" BENTON BASE CAP

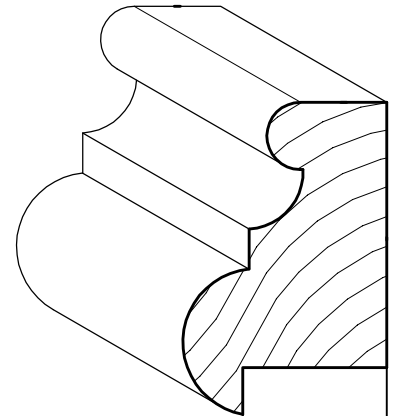

SMC-412
1/16" x 1 5/8"
RABBETED BASE CAP
USE W/ 3/4" BASEBOARD

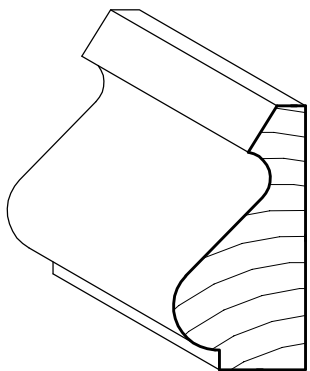

SMC-163
1/16" x 1 3/8" BASE CAP

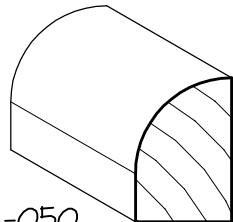

SMC-050
1/2" x 3/4" SHOE MOULD

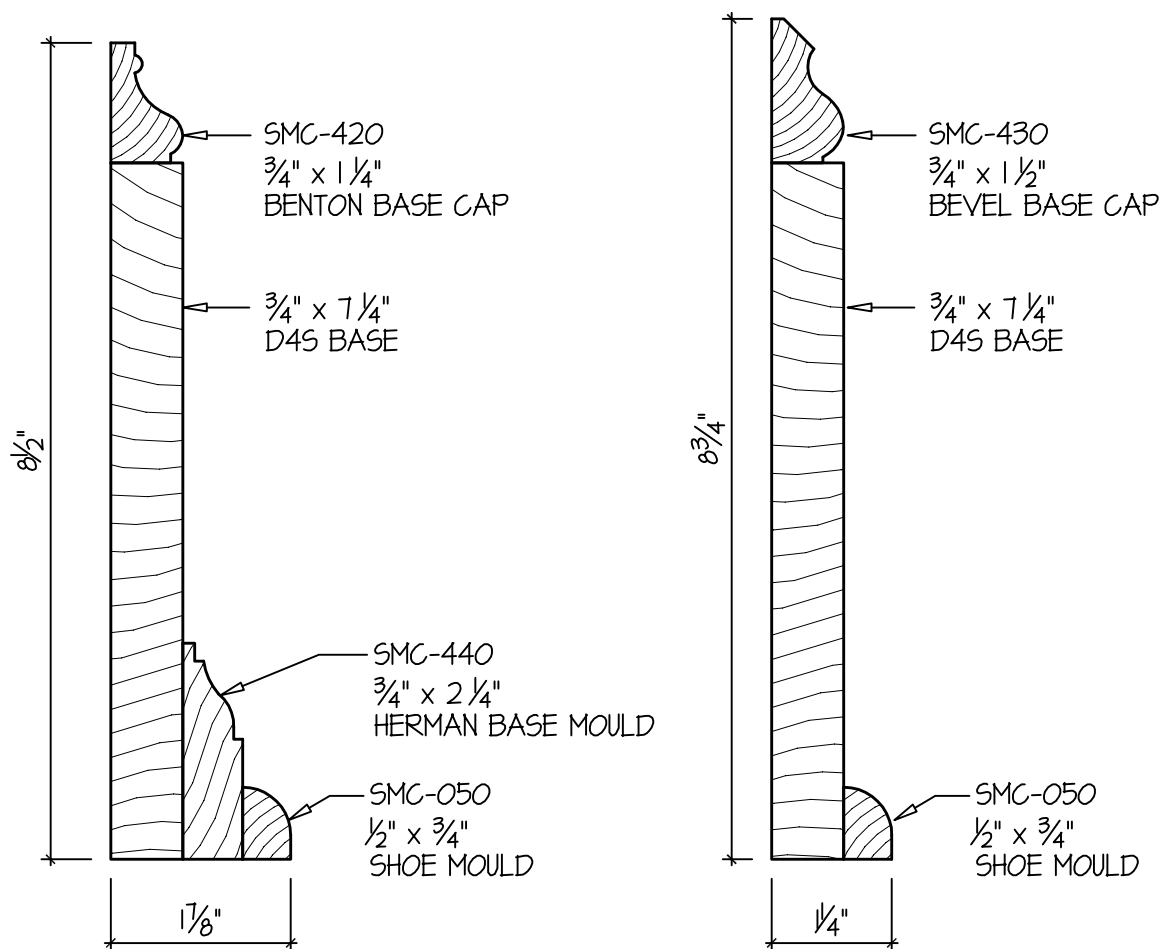

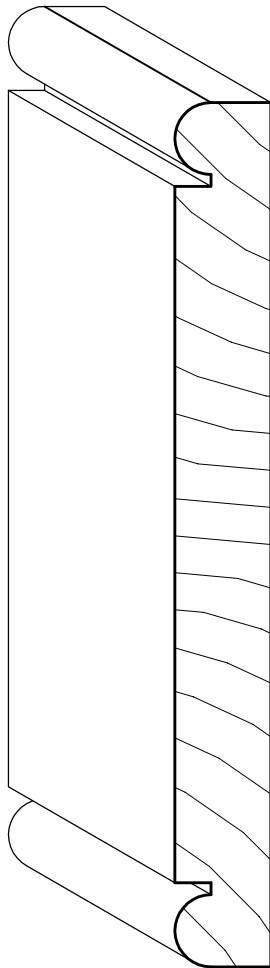

BEADED 2 EDGES
 SMC-474 1/2" x 4"
 SMC-475 1/2" x 4 1/2"
 SMC-476 1/2" x 5"
 SMC-477 1/2" x 5 1/2"

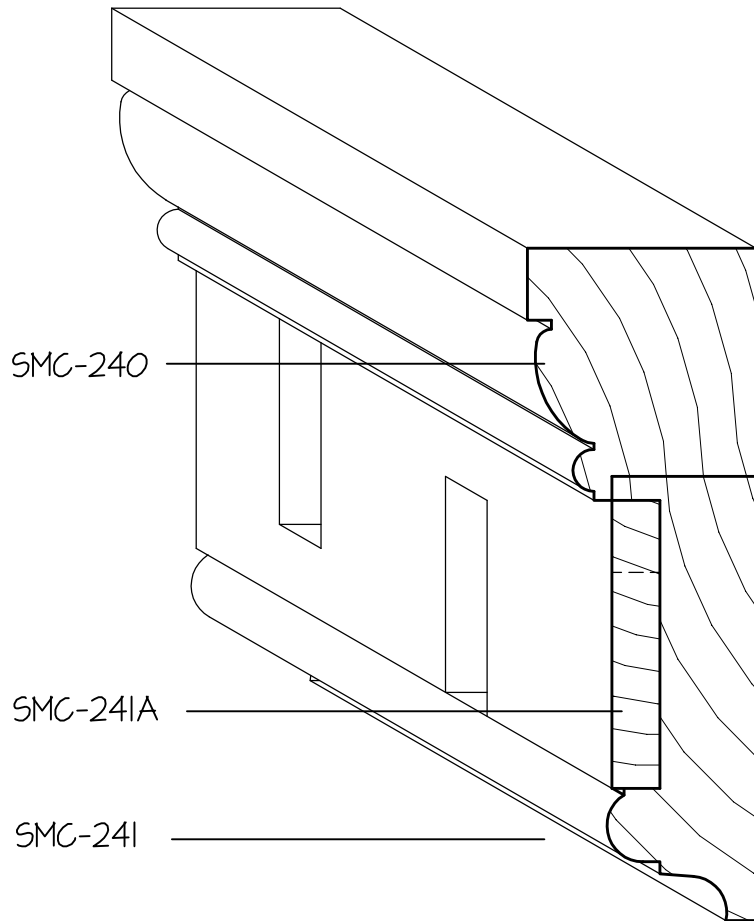

BENTON CHAIR RAIL, 3 PC.

SMC-240 1 3/16" x 1 5/16"
 SMC-241 3/4" x 2 5/16"
 SMC-241A 1/4" x 1 1/2"

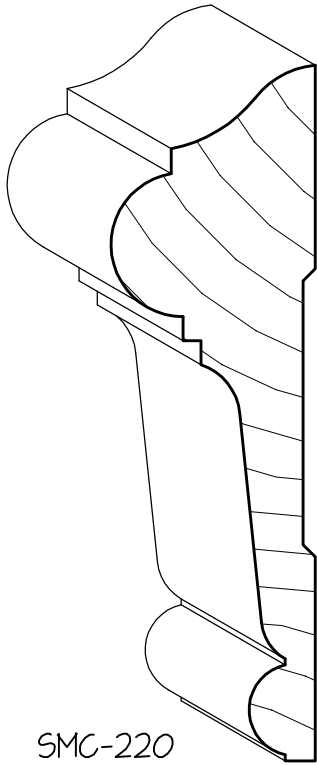

SMC-220
1 1/16" x 3 5/8" CHAIR RAIL

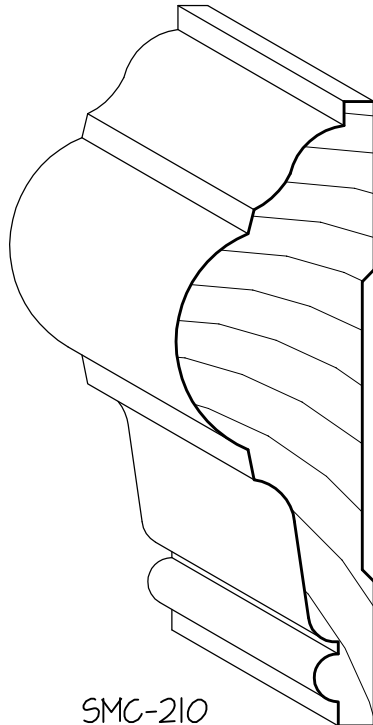

SMC-210
1 1/16" x 3 1/4" CHAIR RAIL

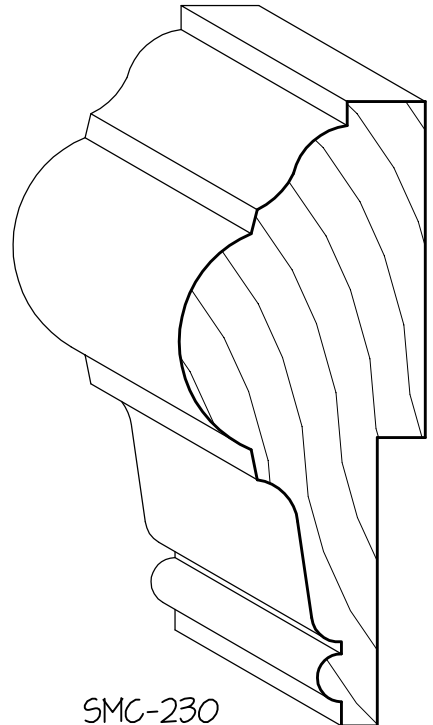

SMC-230
1 5/16" x 3 1/4" CHAIR RAIL,
RABBETED

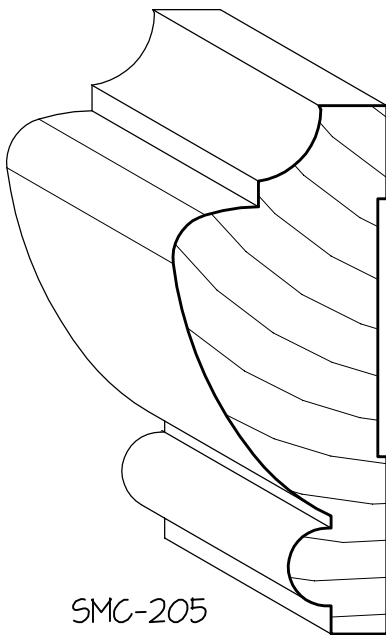

SMC-205
1 1/8" x 2 3/4"
BARRUS CHAIR RAIL

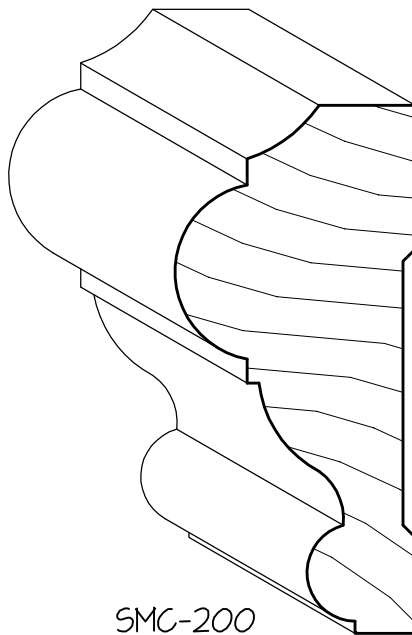

SMC-200
1 1/4" x 2 3/4" CHAIR RAIL

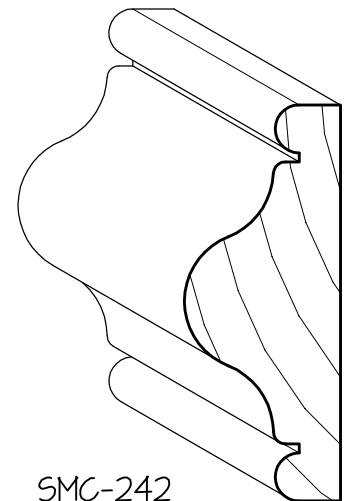

SMC-242
1 3/16" x 2 1/16" CHAIR RAIL

SMC-965
PILASTER CAP

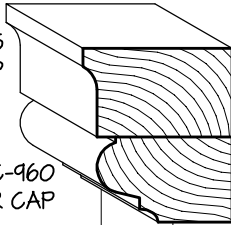

SMC-960
PILASTER CAP

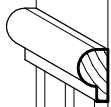

SMC-970
1/2" x 7/8" NECK MOULD

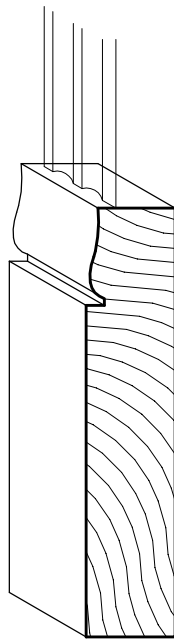
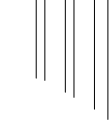

SMC-966
1 1/2" x 7 1/4"
PILASTER BASE

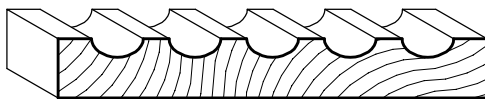

SMC-980
1" x 7 1/4" FLUTED PILASTER

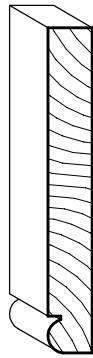

SMC-442
3/4" x 5 1/2"
BEADED | EDGE

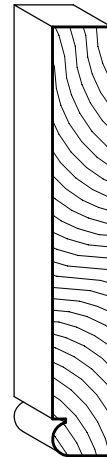

SMC-498
1" x 7 1/4"
BEADED | EDGE

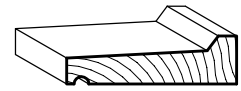

SMC-362
1 3/16" x 2 7/8" DRIP CAP



SMC-361
1 3/16" x 2" DRIP CAP

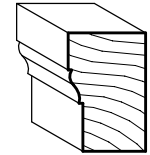

SMC-360
1 5/16" x 2"
ANDERSON
BRICK MOULD

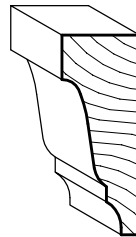

SMC-180
1 3/8" x 3 3/8"
RAKE MOULD

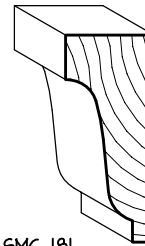

SMC-181
1 1/2" x 3 1/2"
RAKE MOULD

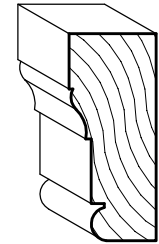

SMC-370
1 1/2" x 3 1/2" BRICK MOULD

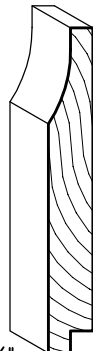

SMC-941
3/4" x 5 1/2"
GERMAN SIDING



SMC-944
3/4" x 5 1/2"
SHIPLAP SIDING

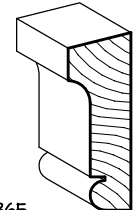

SMC-365
1 1/8" x 3" EXTERIOR
WINDOW SILL APRON

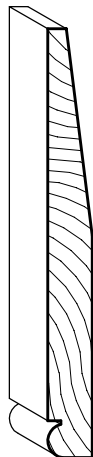

SMC-942
3/4" x 7 1/4"
BEADED
BEVEL SIDING



SMC-946
3/4" x 7 1/4"
BEVEL SIDING

THIS PAGE NOT TO SCALE



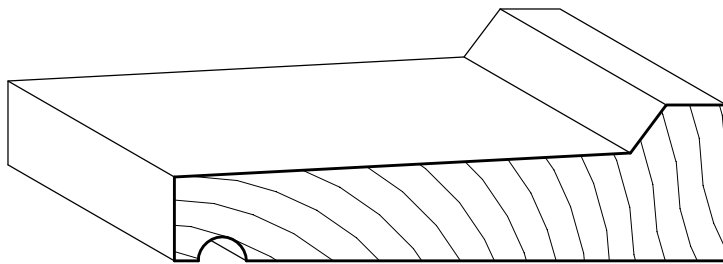

SMC-362
1 3/16" x 2 7/8" DRIP CAP

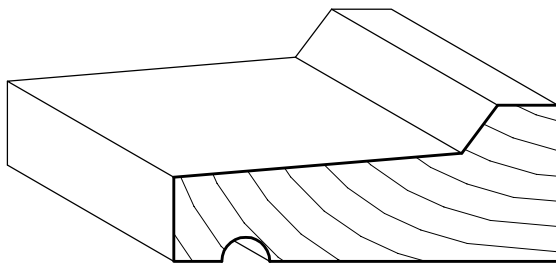

SMC-361
1 3/16" x 2" DRIP CAP

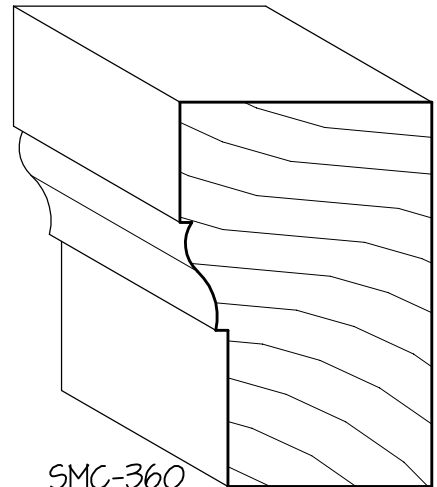

SMC-360
1 5/16" x 2"
ANDERSON BRICK MOULD

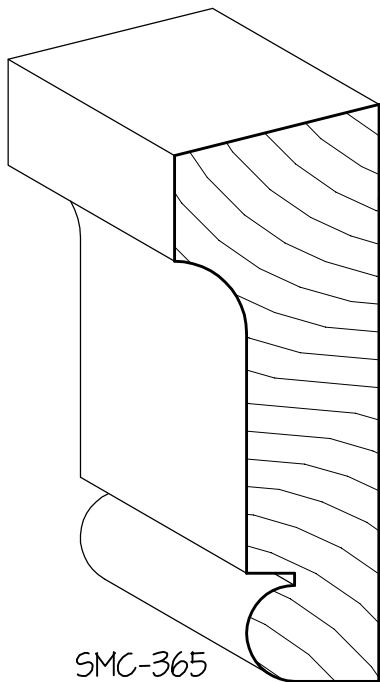

SMC-365
1 1/16" x 3" EXTERIOR
WINDOW SILL APRON

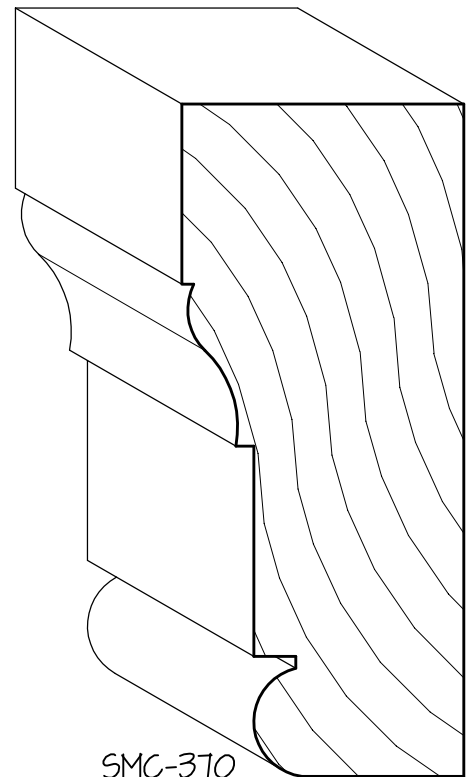

SMC-370
1 1/2" x 3 1/2" BRICK MOULD

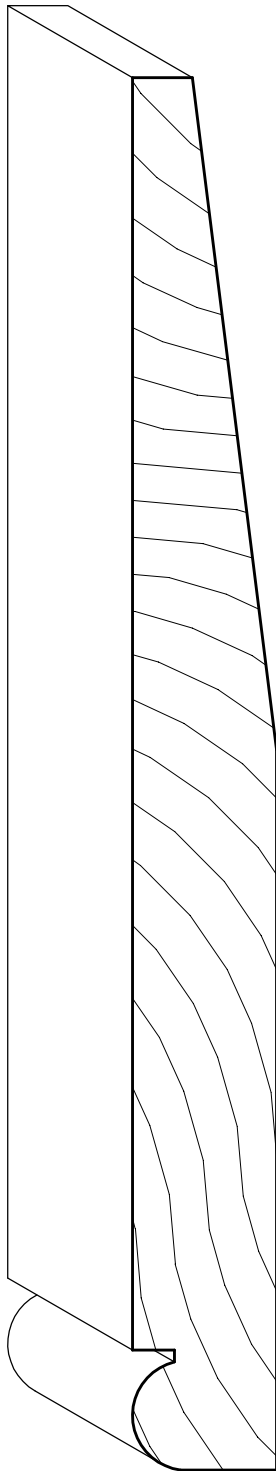

BEADED BEVEL SIDING

SMC-942 $\frac{3}{4}$ " x $7\frac{1}{4}$ "
 SMC-943 $\frac{3}{4}$ " x $9\frac{1}{4}$ "

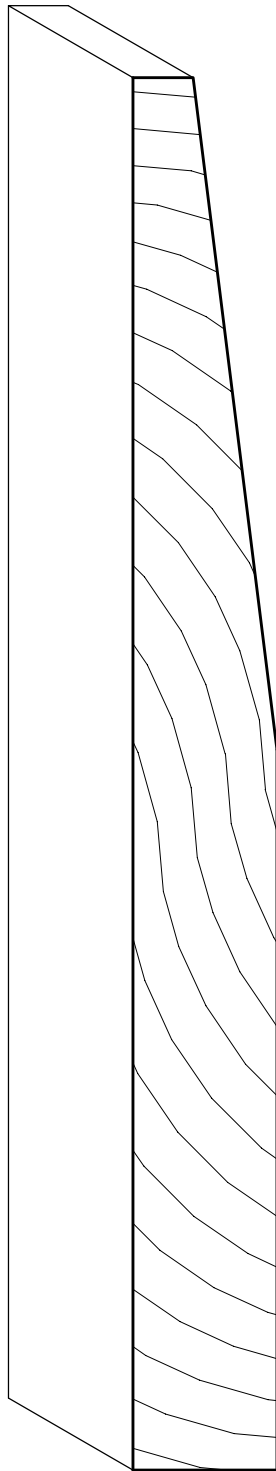

BEVEL SIDING

SMC-946 $\frac{3}{4}$ " x $7\frac{1}{4}$ "
 SMC-947 $\frac{3}{4}$ " x $9\frac{1}{4}$ "

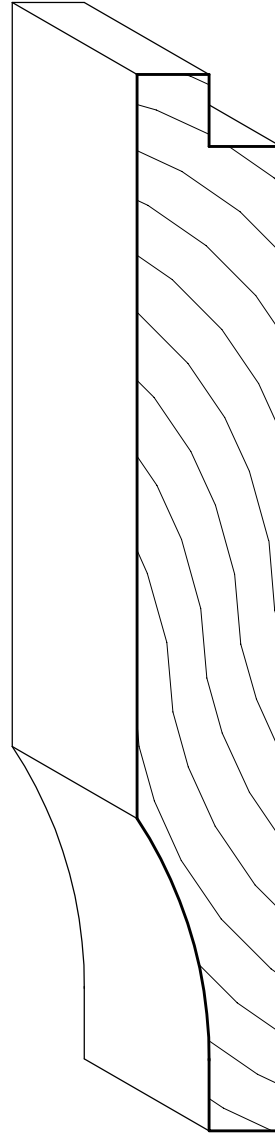

GERMAN SIDING

SMC-951 $\frac{3}{4}$ " x $5\frac{1}{2}$ "
 SMC-952 $\frac{3}{4}$ " x $7\frac{1}{4}$ "
 SMC-953 $\frac{3}{4}$ " x $9\frac{1}{4}$ "

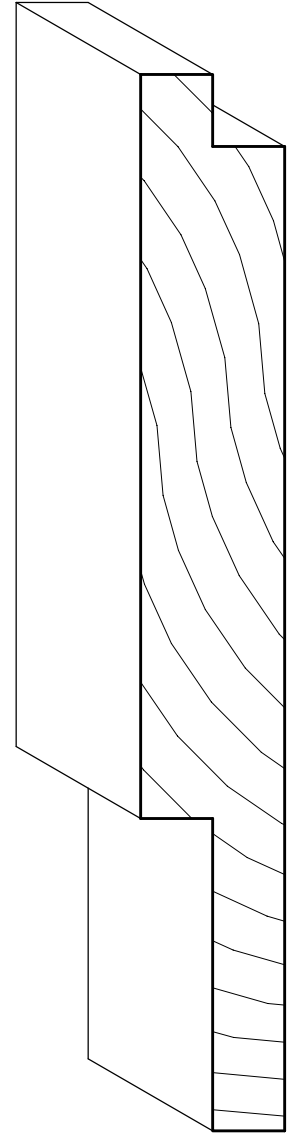

SHIPLAP SIDING

SMC-955 $\frac{3}{4}$ " x $5\frac{1}{2}$ "
 SMC-956 $\frac{3}{4}$ " x $7\frac{1}{4}$ "
 SMC-957 $\frac{3}{4}$ " x $9\frac{1}{4}$ "

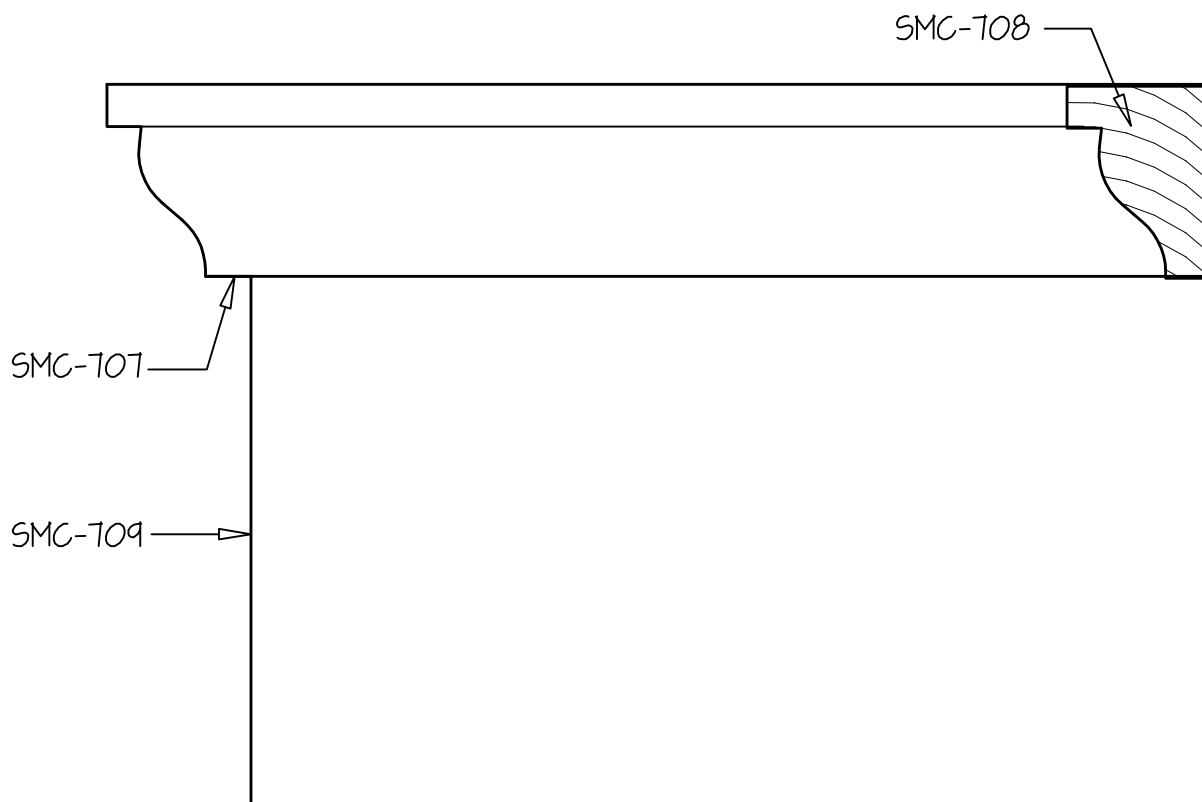

SMC-709 SQUARE MODILLION BLOCK, $2\frac{3}{4}$ " x $3\frac{1}{2}$ " x 5"
 SMC-707 MODILLION PLATE, 1" x $4\frac{1}{2}$ " x $5\frac{1}{2}$ "
 SMC-708 MODILLION MOULDING, $\frac{3}{4}$ " x 1"

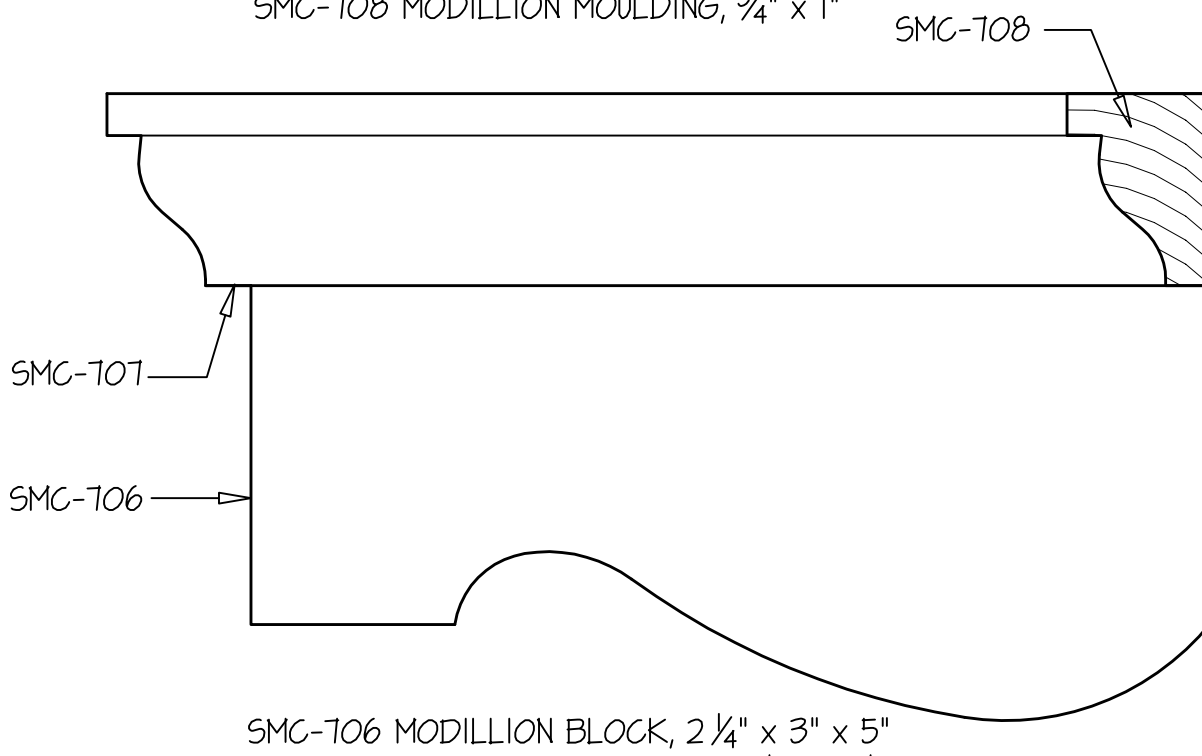

SMC-706 MODILLION BLOCK, $2\frac{1}{4}$ " x 3" x 5"
 SMC-707 MODILLION PLATE, 1" x $4\frac{1}{2}$ " x $5\frac{1}{2}$ "
 SMC-708 MODILLION MOULDING, $\frac{3}{4}$ " x 1"

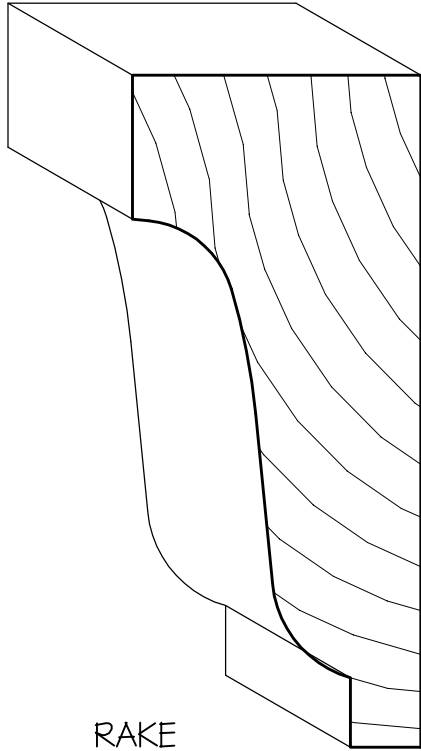

RAKE
SMC-181 $1\frac{1}{2}'' \times 3\frac{1}{2}''$

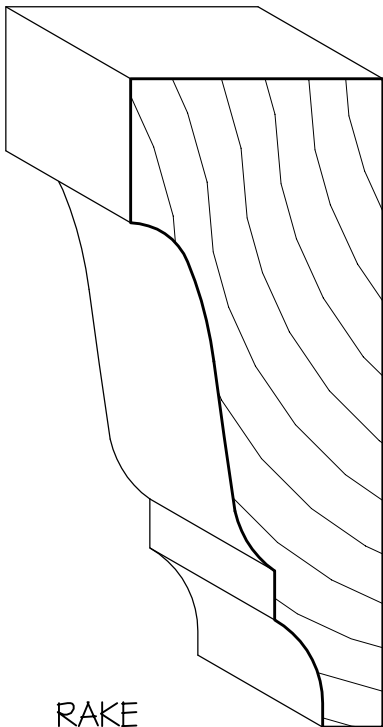

RAKE
SMC-180 $1\frac{3}{8}'' \times 3\frac{3}{8}''$



BEADED 1 EDGE
SMC-491 $\frac{3}{4}'' \times 3\frac{1}{2}''$
SMC-492 $\frac{3}{4}'' \times 5\frac{1}{2}''$
SMC-493 $\frac{3}{4}'' \times 7\frac{1}{4}''$
SMC-494 $\frac{3}{4}'' \times 9\frac{1}{4}''$

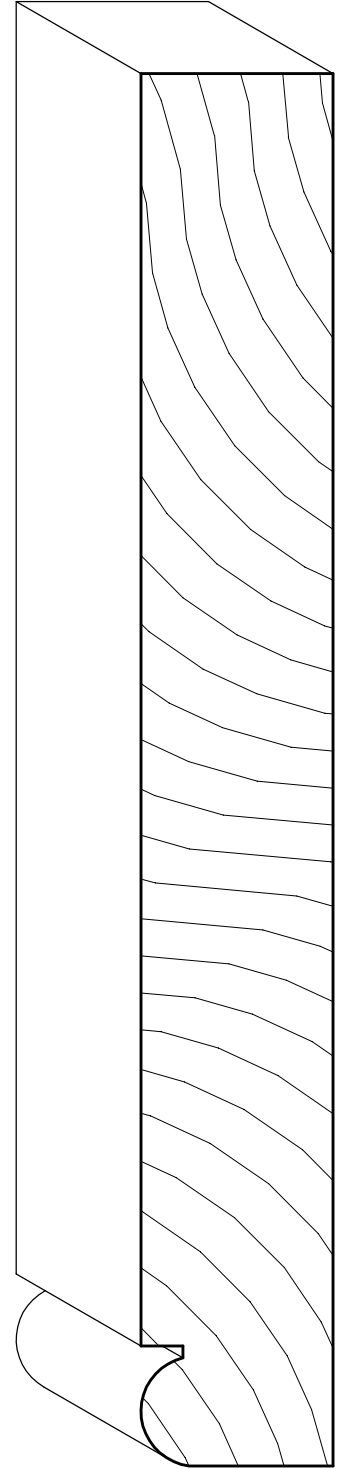

BEADED 1 EDGE
SMC-496 $1'' \times 3\frac{1}{2}''$
SMC-497 $1'' \times 5\frac{1}{2}''$
SMC-498 $1'' \times 7\frac{1}{4}''$
SMC-499 $1'' \times 9\frac{1}{4}''$

SMC-965
1 1/2" x 2 1/2" PILASTER CAP

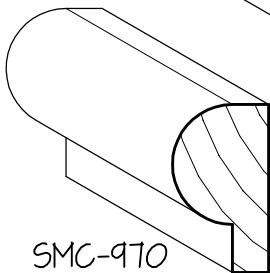
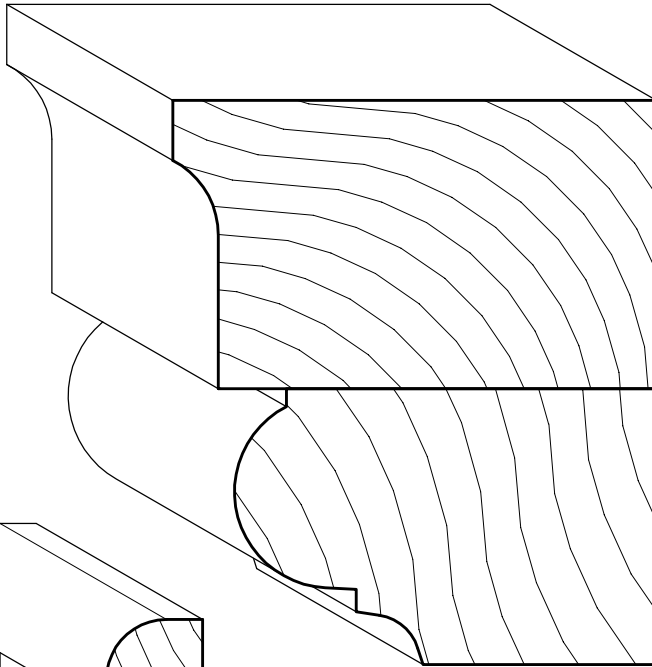

SMC-970
1/2" x 1/8" NECK MOULD

SMC-960
1 1/2" x 2 1/4" PILASTER CAP

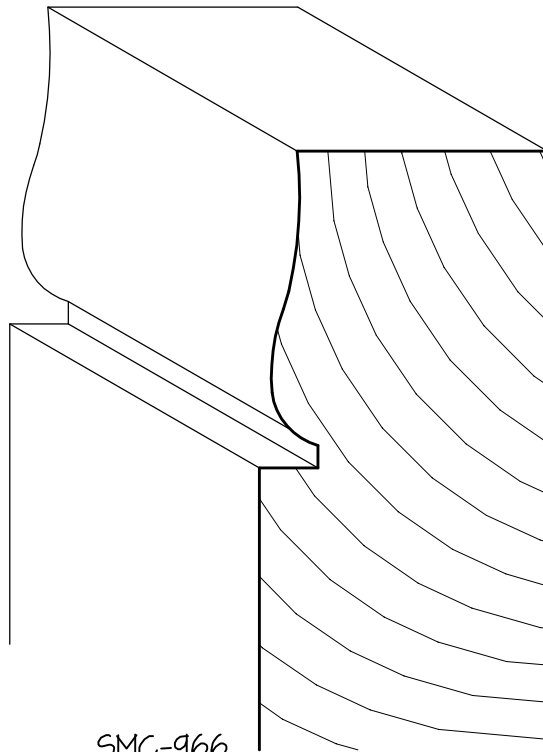

SMC-966
1 1/2" x 1 1/4" PILASTER BASE

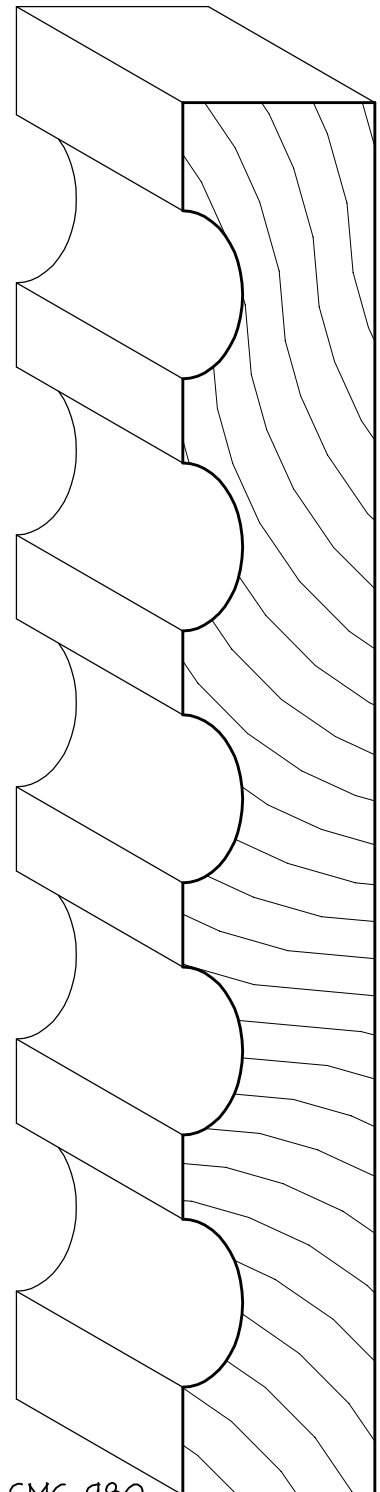

SMC-980
1" x 1 1/4" FLUTED PILASTER

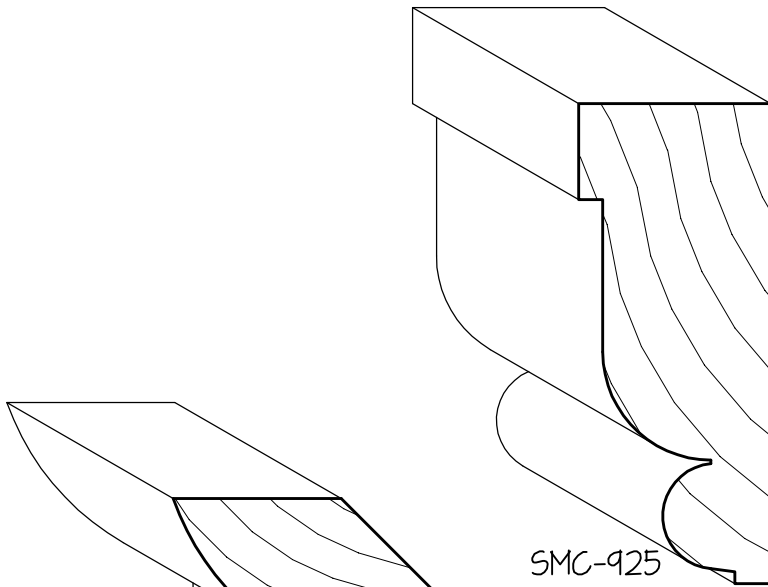

SMC-925
1" x 2 1/2"
MANTLE SURROUND

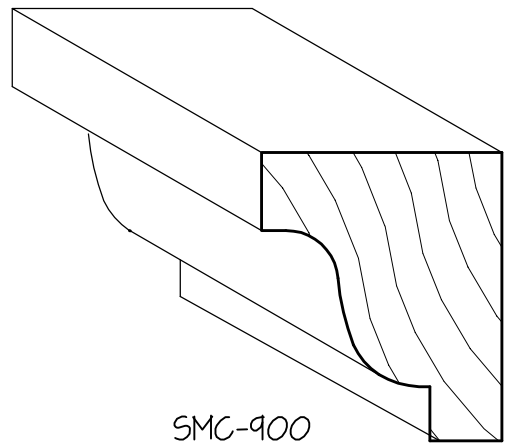

SMC-900
1/4" x 1 1/2" HEAD MOULD

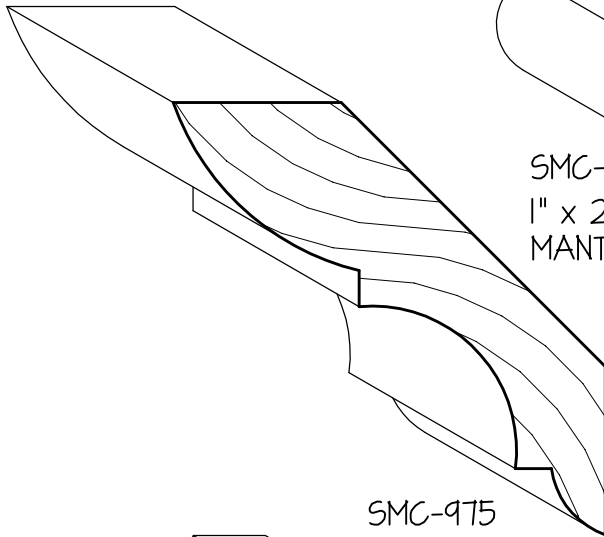

SMC-975
3/4" x 3 1/4" MANTLE CROWN

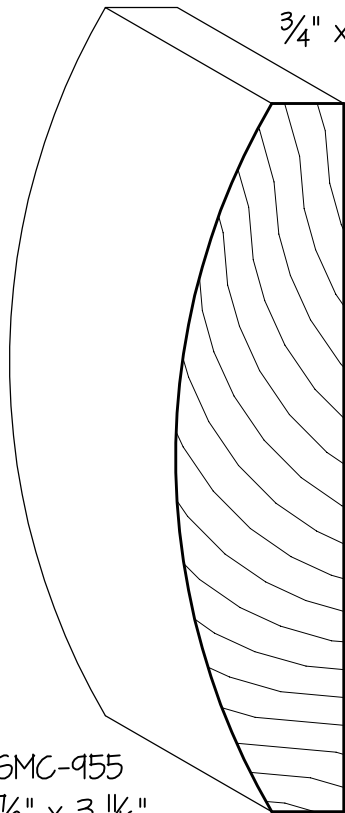

SMC-955
7/8" x 3 1/16"
MANTLE BREAST MOULD

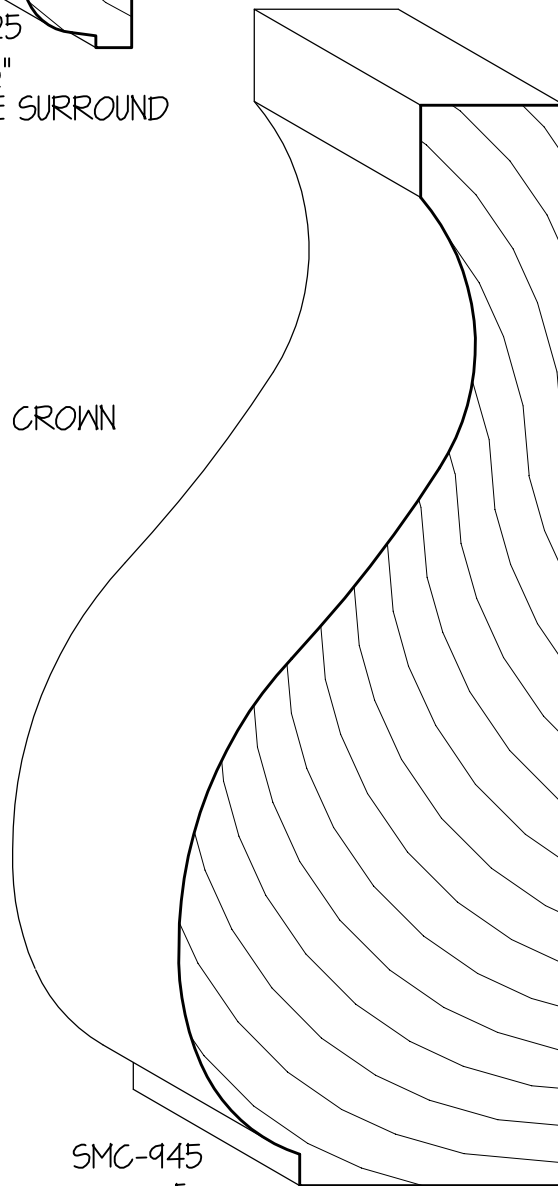

SMC-945
2" x 5 5/8"
MANTLE BREAST MOULD

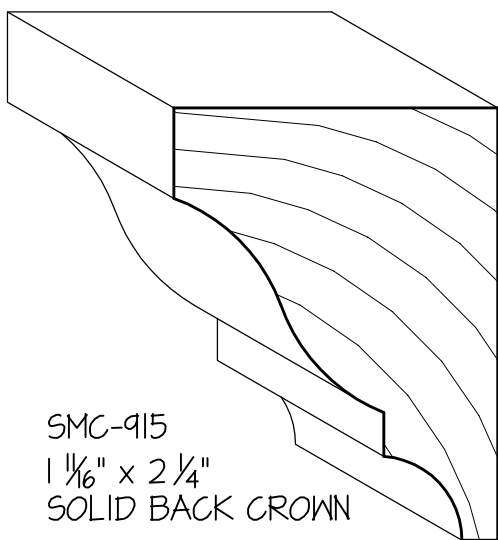

SMC-915
1 1/16" x 2 1/4"
SOLID BACK CROWN

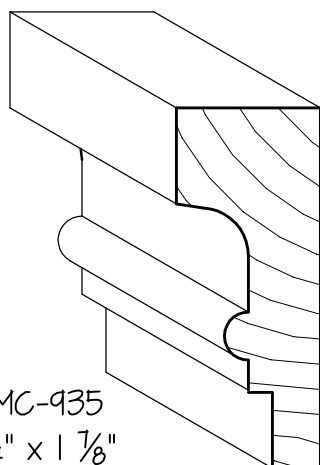

SMC-935
3/4" x 1 7/8"
MANTLE MOULD

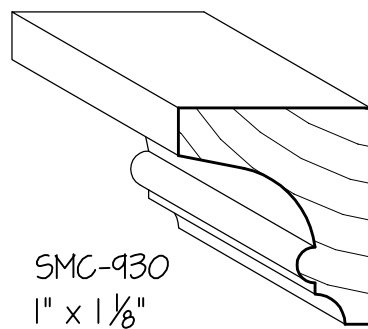

SMC-930
1" x 1 1/8"
MANTLE MOULD

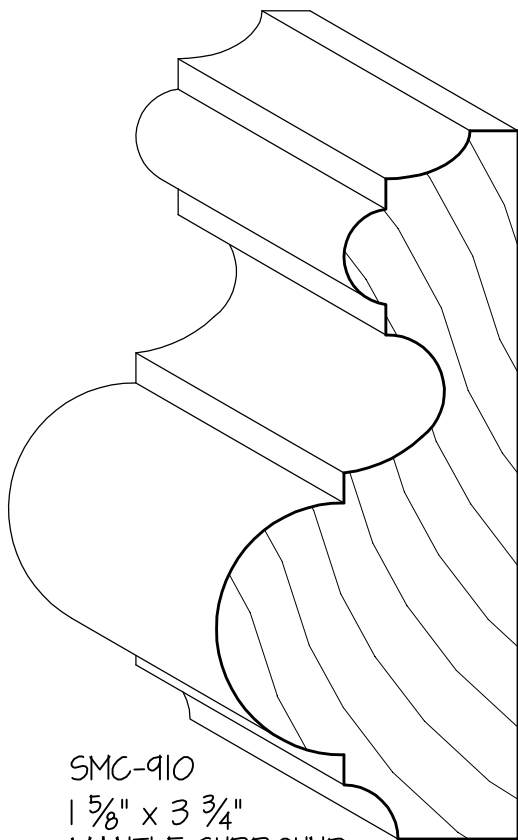

SMC-910
1 5/8" x 3 3/4"
MANTLE SURROUND

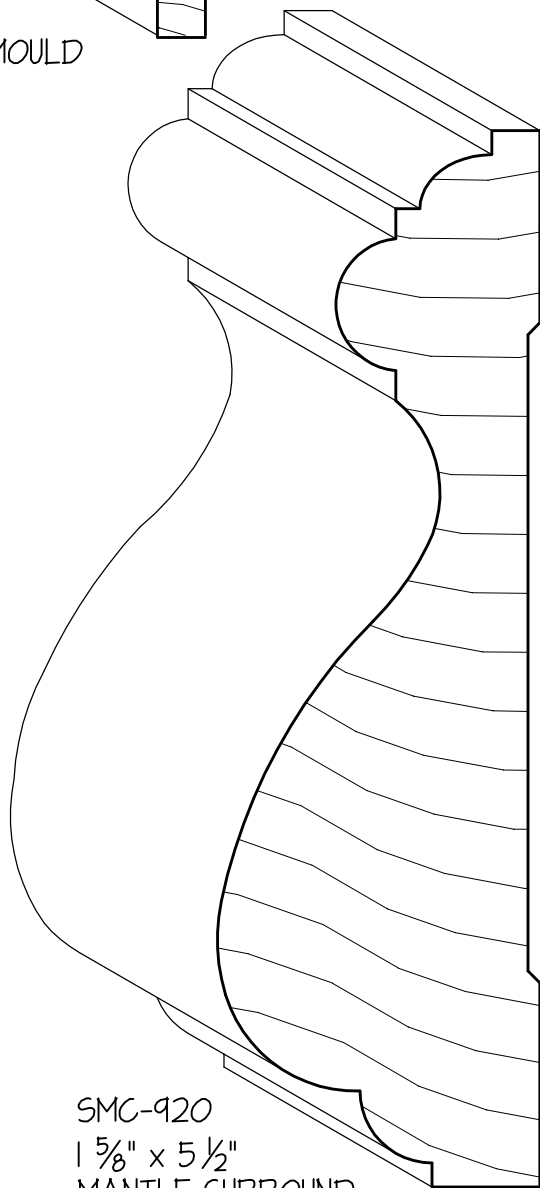

SMC-920
1 5/8" x 5 1/2"
MANTLE SURROUND

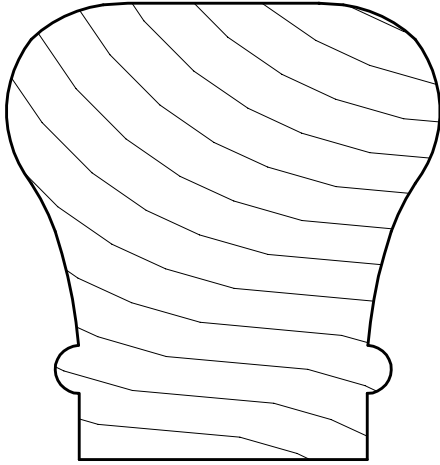

SMC-6010
2 1/4" x 2 3/8" HANDRAIL

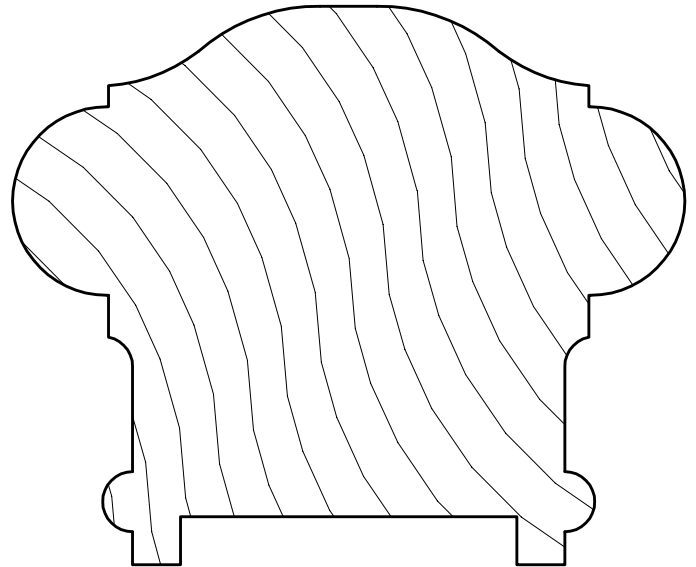

SMC-604
3 1/2" x 3" HANDRAIL

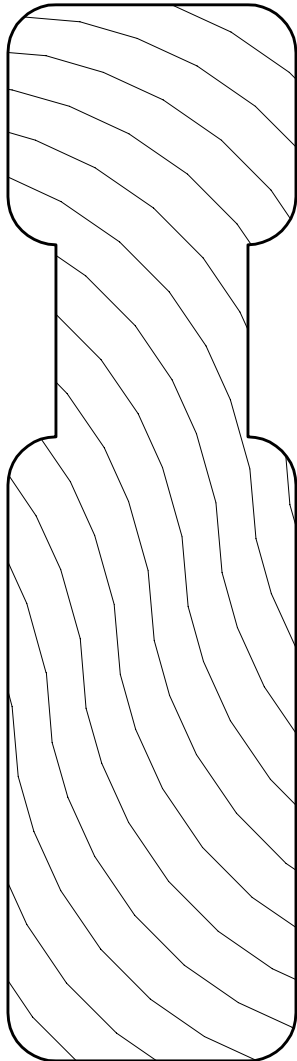

SMC-601
1 1/2" x 5 1/2" HAND RAIL

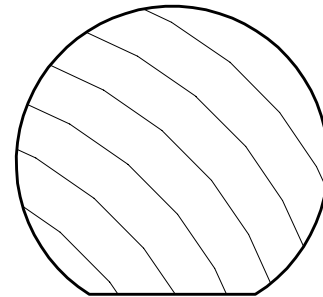

SMC-6040
1 5/8" x 1 1/2" HANDRAIL

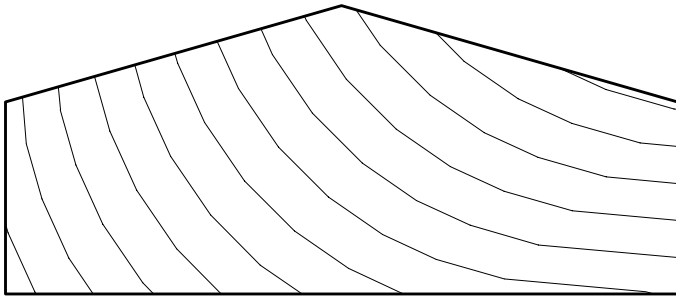

SMC-602
1 1/2" x 3 1/2" DECK RAIL

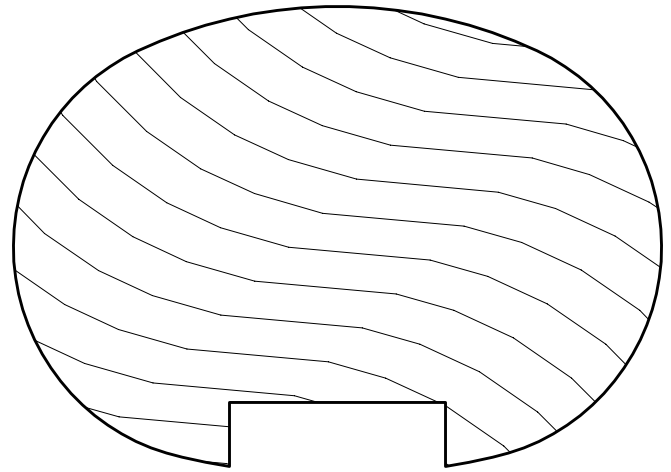

SMC-605
3 3/8" x 2 3/8" HANDRAIL

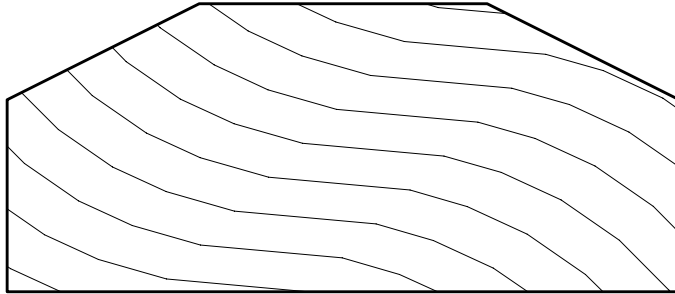

SMC-603
1 1/2" x 3 1/2" DECK RAIL

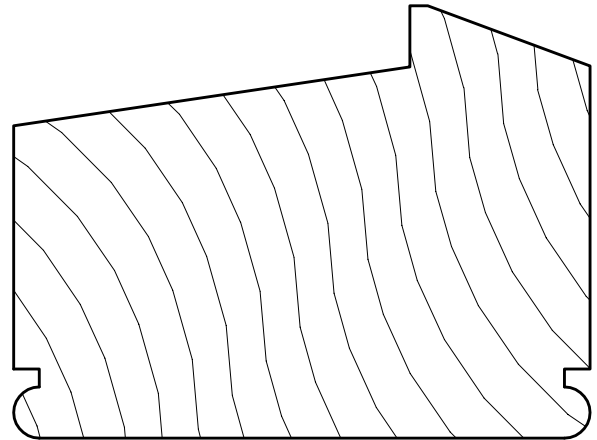

SMC-606
3" x 2 1/4" BOTTOM RAIL

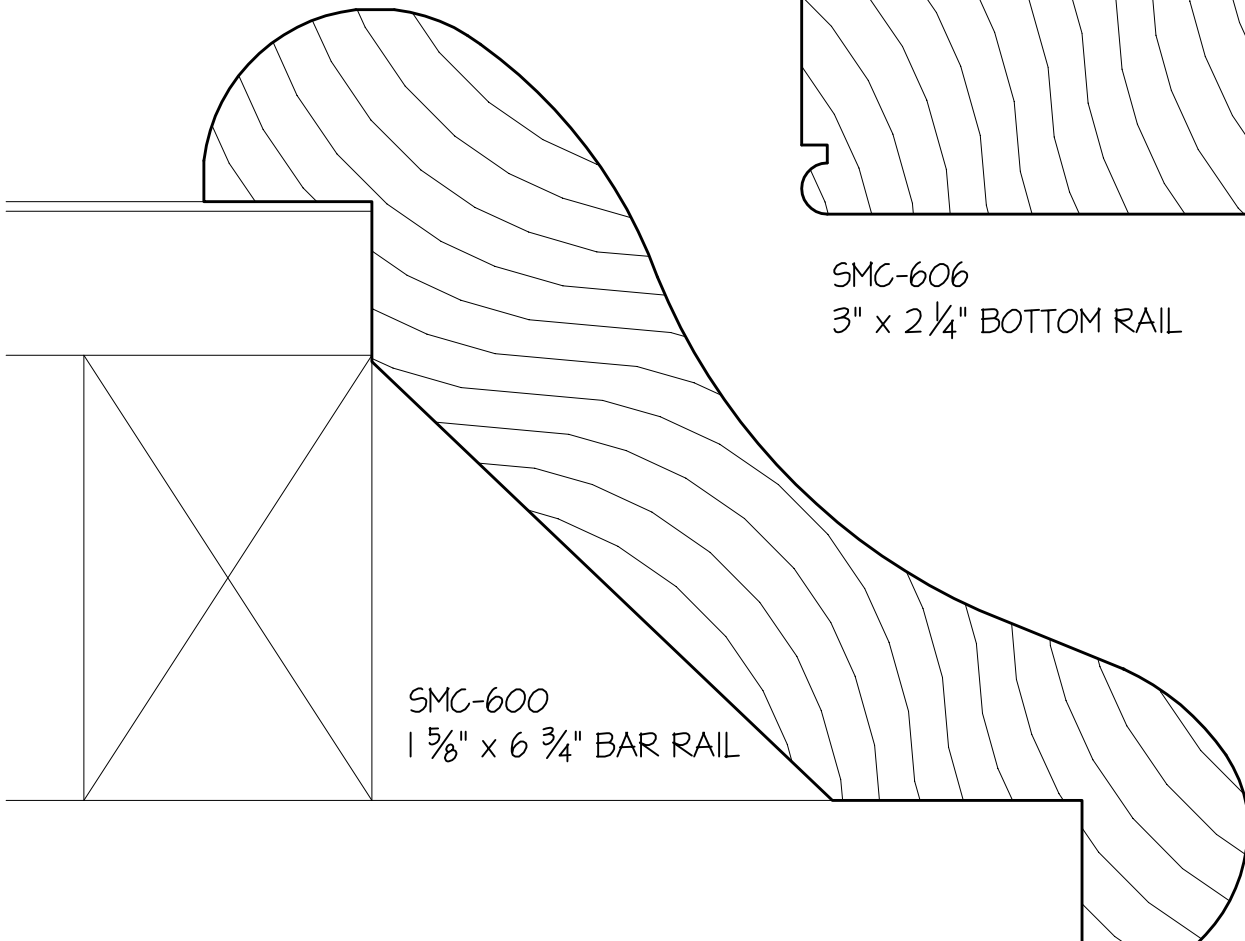

SMC-600
1 5/8" x 6 3/4" BAR RAIL

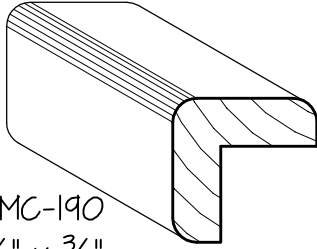

SMC-190
 $\frac{3}{4}'' \times \frac{3}{4}''$
 OUTSIDE CORNER

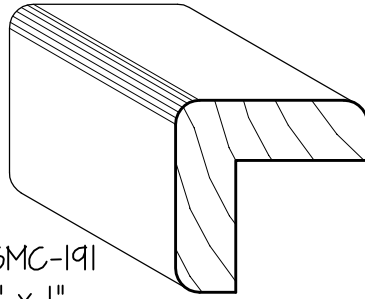

SMC-191
 1" x 1"
 OUTSIDE CORNER

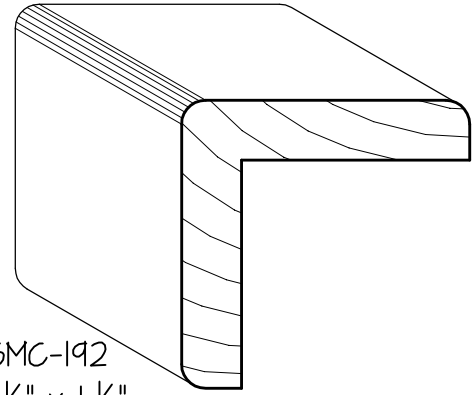

SMC-192
 $1\frac{1}{2}'' \times 1\frac{1}{2}''$
 OUTSIDE CORNER

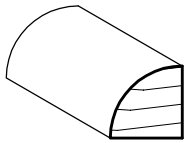

SMC-260
 $\frac{3}{8}'' \times \frac{3}{8}''$
 QUARTER ROUND

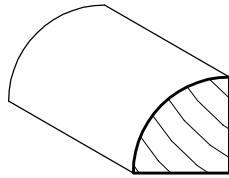

SMC-263
 $\frac{1}{2}'' \times \frac{1}{2}''$
 QUARTER ROUND

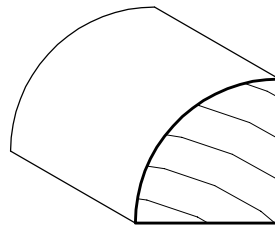

SMC-265
 $\frac{3}{4}'' \times \frac{3}{4}''$
 QUARTER ROUND

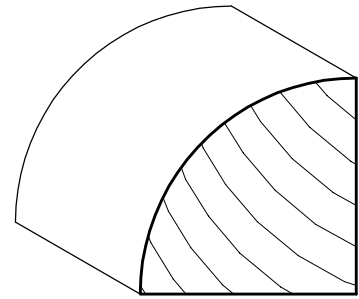

SMC-267
 $\frac{1}{8}'' \times \frac{1}{8}''$
 QUARTER ROUND

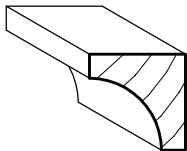

SMC-121
 $\frac{1}{2}'' \times \frac{1}{2}''$
 COVE MOULD

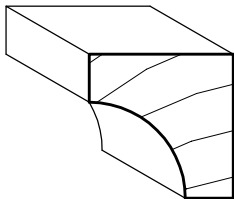

SMC-122
 $\frac{3}{4}'' \times \frac{3}{4}''$
 COVE MOULD

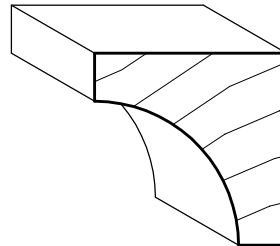

SMC-123
 1" x 1"
 COVE MOULD

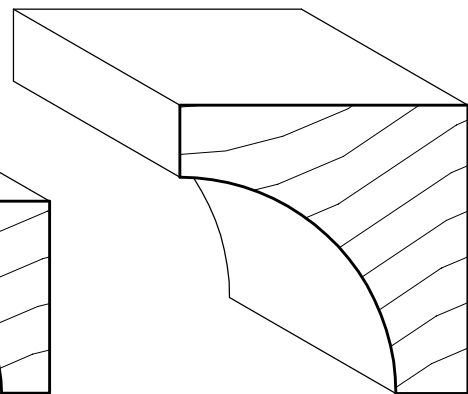

SMC-124
 $1\frac{1}{2}'' \times 1\frac{1}{2}''$
 COVE MOULD

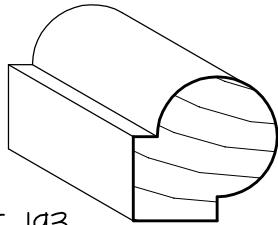

SMC-193
3/4" CORNER BEAD

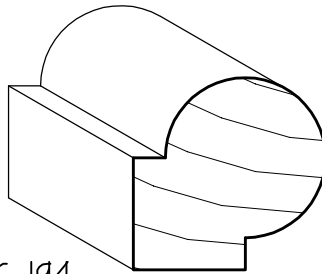

SMC-194
1" CORNER BEAD

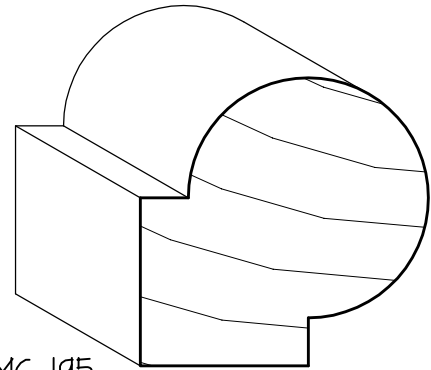

SMC-195
1 1/2" CORNER BEAD

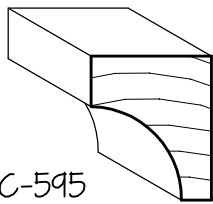

SMC-595
5/8" x 3/4" SCOTIA MOULD

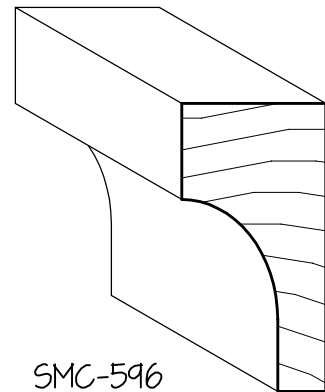

SMC-596
3/4" x 1 1/2" SCOTIA MOULD

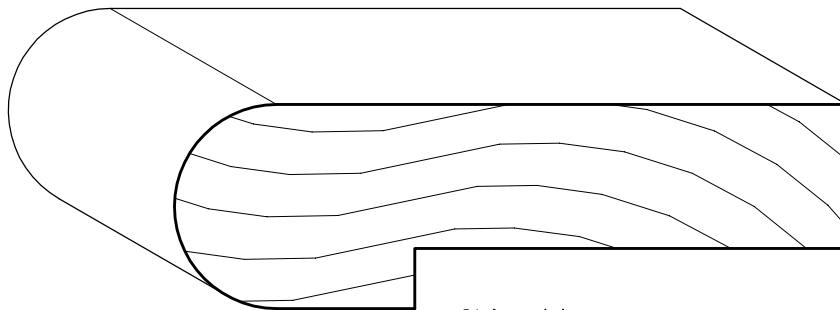

SMC-990
1 1/6" x 3 1/2" STAIR LANDING NOSING
ALSO AVAILABLE IN 5 1/2"

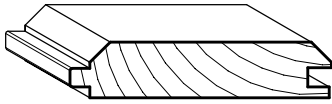

SMC-860 $\frac{3}{4}$ " x $3\frac{1}{2}$ "
T & G "V" PANELING

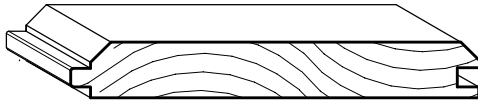

SMC-861 $\frac{3}{4}$ " x $5\frac{1}{2}$ "
T & G "V" PANELING

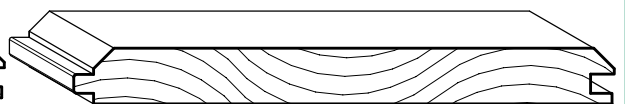

SMC-862 $\frac{3}{4}$ " x $7\frac{1}{4}$ "
T & G "V" PANELING

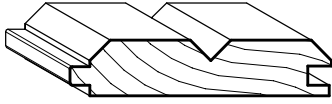

SMC-864 $\frac{3}{4}$ " x $3\frac{1}{2}$ "
T & G "V" PANELING

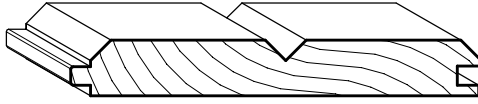

SMC-865 $\frac{3}{4}$ " x $3\frac{1}{2}$ "
T & G "V" PANELING

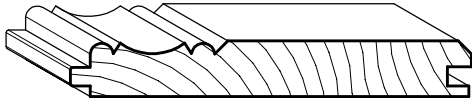

SMC-871 $\frac{5}{8}$ " x $5\frac{1}{2}$ "
T & G PICKWICK PANELING

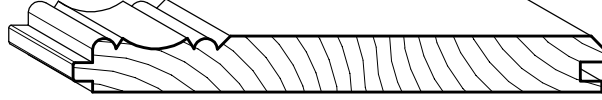

SMC-872 $\frac{5}{8}$ " x $7\frac{1}{4}$ "
T & G PICKWICK PANELING

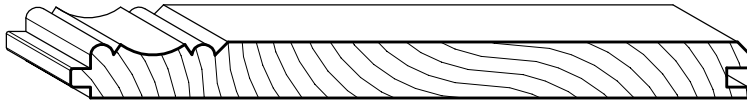

SMC-873 $\frac{5}{8}$ " x $9\frac{1}{4}$ "
T & G PICKWICK PANELING

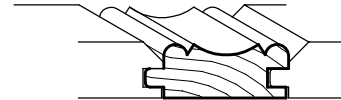

SMC-870 $\frac{3}{4}$ " x 2"
T & G PICKWICK PANELING INSERT



SMC-895 $\frac{3}{4}$ " x $3\frac{1}{2}$ "
T & G QTR. ROUND PANELING



SMC-896 $\frac{3}{4}$ " x $5\frac{1}{2}$ "
T & G QTR. ROUND PANELING

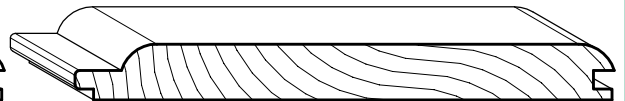

SMC-897 $\frac{3}{4}$ " x $7\frac{1}{4}$ "
T & G QTR. ROUND PANELING

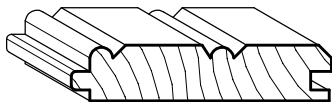

SMC-840 $\frac{3}{4}$ " x $3\frac{1}{2}$ "
T & G DBL. BEADED PANELING

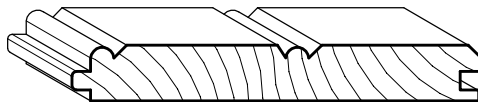

SMC-841 $\frac{3}{4}$ " x $5\frac{1}{2}$ "
T & G DBL. BEADED PANELING

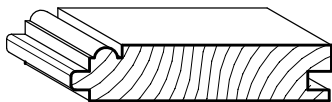

SMC-880 $\frac{3}{4}$ " x $3\frac{1}{2}$ "
T & G BEADED PANELING

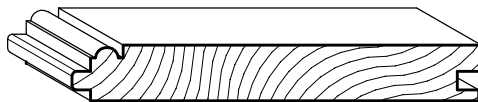

SMC-881 $\frac{3}{4}$ " x $5\frac{1}{2}$ "
T & G BEADED PANELING



SMC-882 $\frac{3}{4}$ " x $7\frac{1}{4}$ "
T & G BEADED PANELING

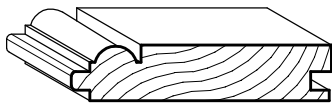

SMC-890 $\frac{3}{4}$ " x $3\frac{1}{2}$ "
T & G BEADED PANELING

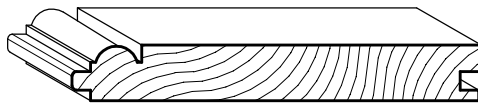

SMC-891 $\frac{3}{4}$ " x $5\frac{1}{2}$ "
T & G BEADED PANELING

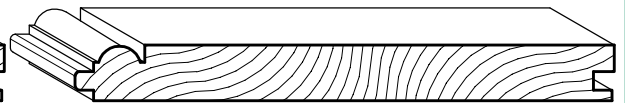

SMC-892 $\frac{3}{4}$ " x $7\frac{1}{4}$ "
T & G BEADED PANELING

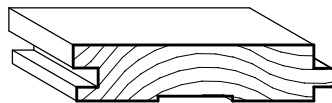

SMC-850
 $\frac{3}{4}$ " x $3\frac{1}{2}$ " T & G FLOORING

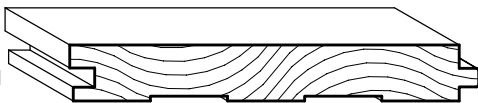

SMC-851
 $\frac{3}{4}$ " x $5\frac{1}{2}$ " T & G FLOORING

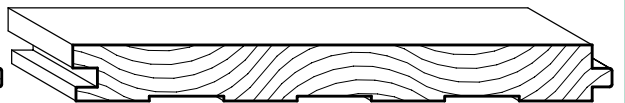

SMC-852
 $\frac{3}{4}$ " x $7\frac{1}{4}$ " T & G FLOORING

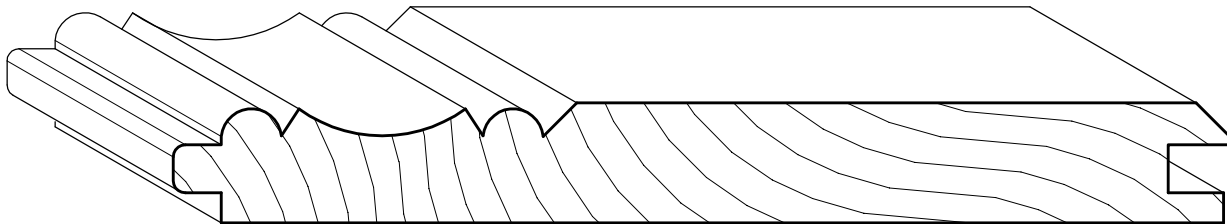

SMC-871 $\frac{5}{8}$ " x $5\frac{1}{2}$ "

T & G PICKWICK PANELING

SMC-872 $\frac{5}{8}$ " x $7\frac{1}{4}$ "

SMC-873 $\frac{5}{8}$ " x $9\frac{1}{4}$ "

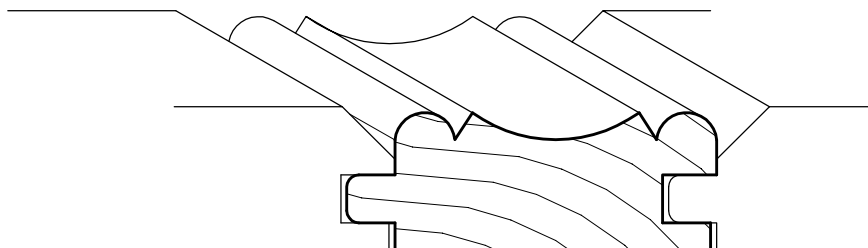

SMC-870 $\frac{3}{4}$ " x 2"

T & G PICKWICK PANELING INSERT

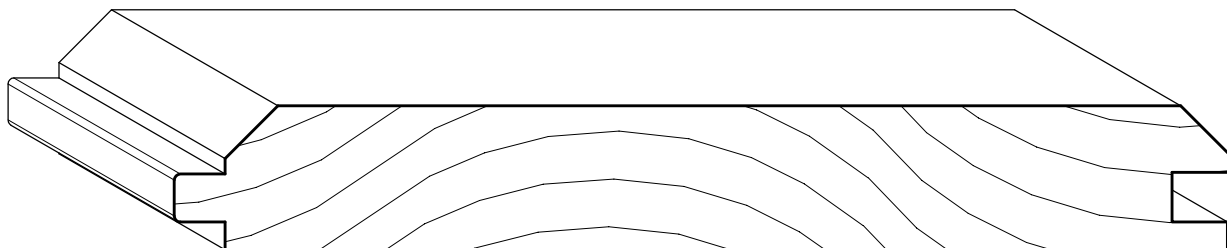

SMC-860 $\frac{3}{4}$ " x $3\frac{1}{2}$ "

T & G "V" PANELING

SMC-861 $\frac{3}{4}$ " x $5\frac{1}{2}$ "

SMC-862 $\frac{3}{4}$ " x $7\frac{1}{4}$ "

SMC-863 $\frac{3}{4}$ " x $9\frac{1}{4}$ "

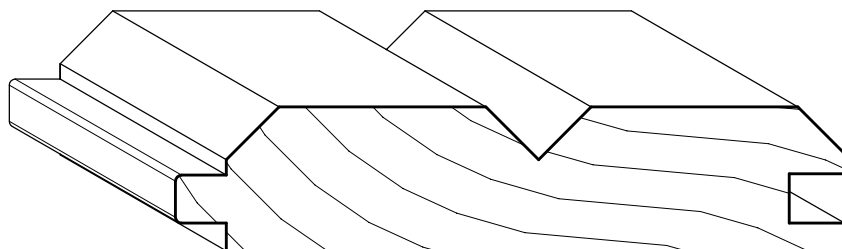

SMC-864 $\frac{3}{4}$ " x $3\frac{1}{2}$ "

T & G DBL. "V" PANELING

SMC-865 $\frac{3}{4}$ " x $5\frac{1}{2}$ "

SMC-840 $\frac{3}{4}$ " x $3\frac{1}{2}$ "
 SMC-841 $\frac{3}{4}$ " x $5\frac{1}{2}$ "

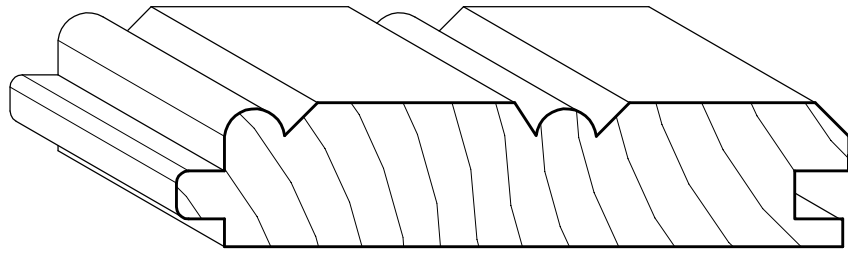

T & G DBL. BEADED PANELING

SMC-880 $\frac{3}{4}$ " x $3\frac{1}{2}$ "
 SMC-881 $\frac{3}{4}$ " x $5\frac{1}{2}$ "
 SMC-882 $\frac{3}{4}$ " x $7\frac{1}{4}$ "
 SMC-883 $\frac{3}{4}$ " x $9\frac{1}{4}$ "

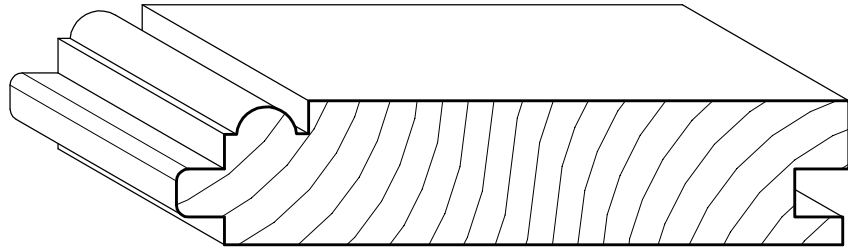

T & G DBL. BEADED PANELING

SMC-890 $\frac{3}{4}$ " x $3\frac{1}{2}$ "
 SMC-891 $\frac{3}{4}$ " x $5\frac{1}{2}$ "
 SMC-892 $\frac{3}{4}$ " x $7\frac{1}{4}$ "
 SMC-893 $\frac{3}{4}$ " x $9\frac{1}{4}$ "

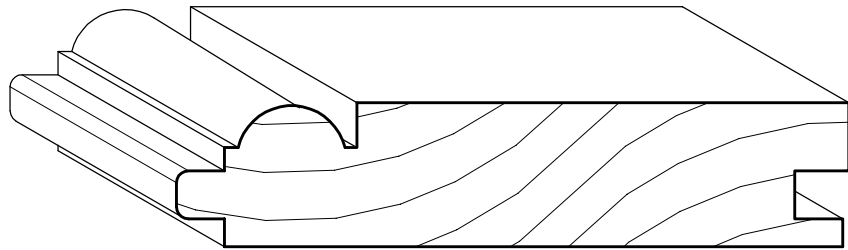

T & G DBL. BEADED PANELING

SMC-895 $\frac{3}{4}$ " x $3\frac{1}{2}$ "
 SMC-896 $\frac{3}{4}$ " x $5\frac{1}{2}$ "
 SMC-897 $\frac{3}{4}$ " x $7\frac{1}{4}$ "
 SMC-898 $\frac{3}{4}$ " x $9\frac{1}{4}$ "

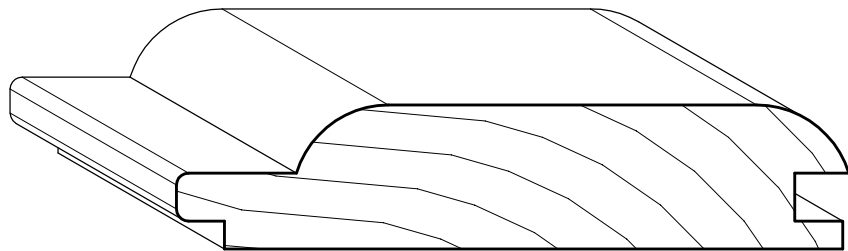

T & G QRT. ROUND PANELING

SMC-850 $\frac{3}{4}$ " x $3\frac{1}{2}$ "
 SMC-851 $\frac{3}{4}$ " x $5\frac{1}{2}$ "
 SMC-852 $\frac{3}{4}$ " x $7\frac{1}{4}$ "
 SMC-853 $\frac{3}{4}$ " x $9\frac{1}{4}$ "

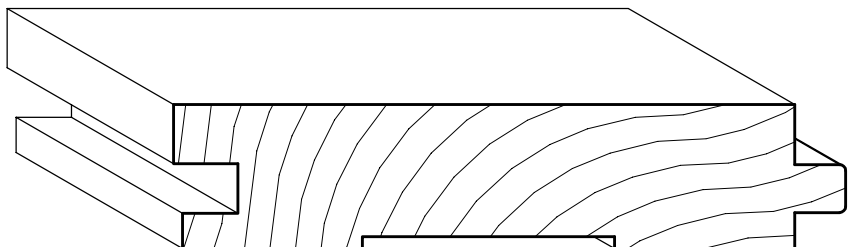

T & G FLOORING

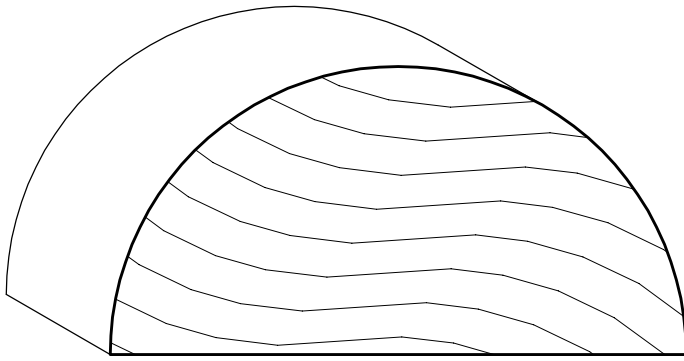

HALF ROUND

- SMC-251 1/2" x 1"
- SMC-252 3/4" x 1 1/2"
- SMC-253 1" x 2"
- SMC-254 1 1/2" x 3"

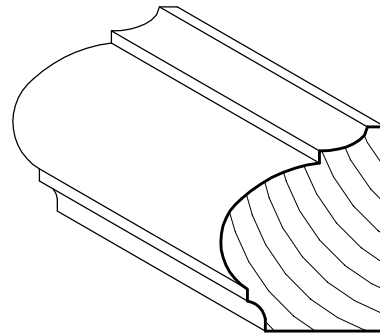

SMC-060

1/8" x 1 1/16" BENTON PANEL MOULD

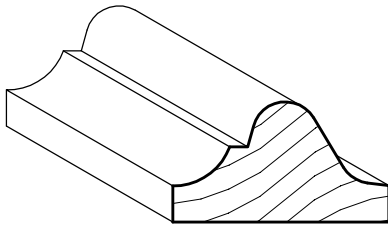

SMC-065

5/8" x 1 1/8" PANEL MOULD

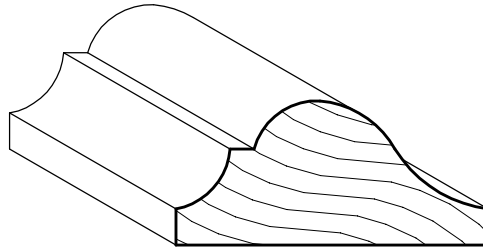

SMC-070

3/4" x 1 5/8" PANEL MOULD

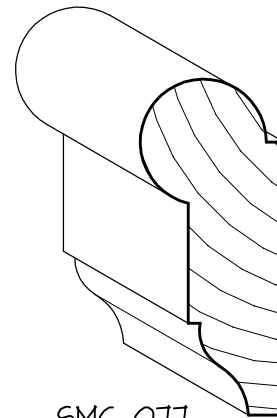

SMC-077

3/4" x 1 3/4" PICTURE MOULD

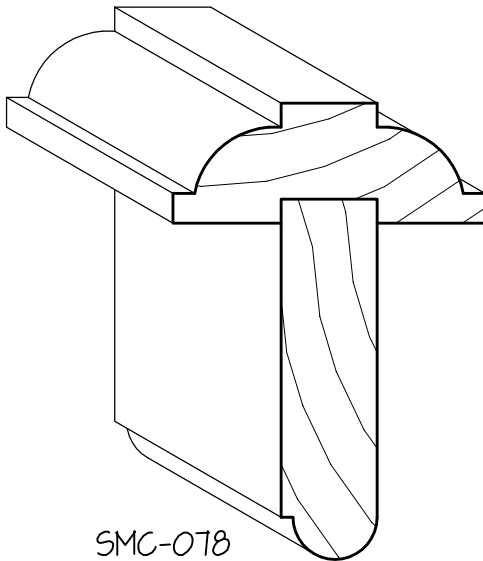

SMC-078

1 5/8" x DOOR THICKNESS
T-ASTRAGAL

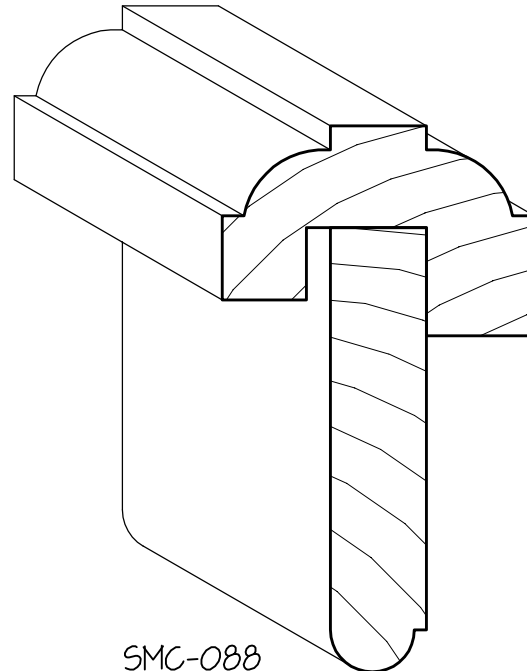

SMC-088

1 5/8" x DOOR THICKNESS
KERFED ASTRAGAL

Stock Number	Moulding Description	PG	Stock Number	Moulding Description	PG	Stock Number	Moulding Description	PG
SMC-561	APRON - BENTON MLD	13	SMC-310	CASING - MOULDED	4	SMC-6040	HANDRAIL	42
SMC-560	APRON - BENTON	13	SMC-320	CASING - MOULDED	4	SMC-601	HANDRAIL	42
SMC-365	APRON - WINDOW SILL	35	SMC-300	CASING - MOULDED	4	SMC-602	HANDRAIL	43
SMC-550	APRON - WINDOW	13	SMC-321	CASING - OGEE	6	SMC-603	HANDRAIL	43
SMC-346B	BACKBAND - BARRUS	9	SMC-353	CASING - RANCH	6	SMC-605	HANDRAIL	43
SMC-020	BACKBAND - BENTON	5	SMC-354	CASING - RANCH	6	SMC-606	HANDRAIL	43
SMC-030	BACKBAND - BENTON	5	SMC-RB3	CASING - RB3	8	SMC-900	HEAD MOULD	40
SMC-015	BACKBAND - OG	5	SMC-322	CASING - REEDED	6	SMC-990	LANDING NOSING	45
SMC-025	BACKBAND - OG	5	SMC-205	CHAIR RAIL - BARRUS	33	SMC-945	MANTLE BREAST	40
SMC-010	BACKBAND - RND EDGE	5	SMC-240	CHAIR RAIL - BENTON	32	SMC-955	MANTLE BREAST	40
SMC-026	BACKBAND	9	SMC-241	CHAIR RAIL - BENTON	32	SMC-975	MANTLE CROWN	40
SMC-027	BACKBAND	9	SMC-241A	CHAIR RAIL - BENTON	32	SMC-930	MANTLE MOULDING	41
SMC-600	BARRAIL	43	SMC-230	CHAIR RAIL - RABBETED	33	SMC-935	MANTLE MOULDING	41
SMC-830	BASE - BENTON	29	SMC-242	CHAIR RAIL - SPECIAL	33	SMC-925	MANTLE SURROUND	40
SMC-820	BASE - OG	29	SMC-200	CHAIR RAIL	33	SMC-910	MANTLE SURROUND	41
SMC-650	BASE - SPEED	29	SMC-210	CHAIR RAIL	33	SMC-920	MANTLE SURROUND	41
SMC-420	BASE CAP - BENTON	30	SMC-220	CHAIR RAIL	33	SMC-706	MODILLION BLOCK	37
SMC-838	BASE - CONTEMPORARY	28	SMC-193	CORNER BEAD	45	SMC-709	MODILLION BLOCK	37
SMC-430	BASE CAP - BEVEL	30	SMC-194	CORNER BEAD	45	SMC-708	MODILLION MOULDING	37
SMC-440	BASE CAP - HERMAN	30	SMC-195	CORNER BEAD	45	SMC-707	MODILLION PLATE	37
SMC-414	BASE CAP - OG SKIRT	30	SMC-190	CORNER MOULDING OUTSIDE	44	SMC-470	MULLION BEADED	14
SMC-410	BASE CAP - OG	30	SMC-191	CORNER MOULDING OUTSIDE	44	SMC-460	MULLION BENTON	14
SMC-450	BASE CAP - OG	30	SMC-192	CORNER MOULDING OUTSIDE	44	SMC-704	NECK MOULDING	28
SMC-411	BASE CAP - RABBETED	30	SMC-595	COVE MLD - SCOTIA	45	SMC-970	NECK MOULDING	39
SMC-412	BASE CAP - RABBETED	30	SMC-596	COVE MLD - SCOTIA	45	SMC-703	OG MOULDING	28
SMC-163	BASE CAP	30	SMC-705	COVE MOULDING	28	SMC-060	PANEL MOULDING - BENTON	49
SMC-491	BEADED ONE EDGE	38	SMC-126	COVE MOULDING	19	SMC-065	PANEL MOULDING	49
SMC-496	BEADED ONE EDGE	38	SMC-127	COVE MOULDING	19	SMC-070	PANEL MOULDING	49
SMC-474	BEADED TWO EDGE	32	SMC-128	COVE MOULDING	19	SMC-870	PANELING - INSERT	47
SMC-109	BED MOULDING - W/LEG	16	SMC-125	COVE MOULDING	20	SMC-871	PANELING - PICKWICK	47
SMC-702	BED MOULDING	28	SMC-146	COVE MOULDING	20	SMC-864	PANELING - T&G V GROOVE DBL	47
SMC-101	BED MOULDING	16	SMC-147	COVE MOULDING	20	SMC-860	PANELING - T&G V GROOVE	47
SMC-102	BED MOULDING	16	SMC-140	COVE MOULDING	22	SMC-840	PANELING - T&G BEADED DBL	48
SMC-103	BED MOULDING	16	SMC-141	COVE MOULDING	22	SMC-880	PANELING - T&G BEADED	48
SMC-104	BED MOULDING	16	SMC-142	COVE MOULDING	22	SMC-890	PANELING - T&G BEADED	48
SMC-105	BED MOULDING	24	SMC-143	COVE MOULDING	24	SMC-895	PANELING - T&G QTR RND	48
SMC-360	BRICK MLD - ANDERSEN	35	SMC-121	COVE MOULDING	44	SMC-077	PICTURE MOULD	49
SMC-370	BRICK MLD - BEADED	35	SMC-122	COVE MOULDING	44	SMC-966	PILASTER BASE	39
SMC-341	CASING - 341	7	SMC-123	COVE MOULDING	44	SMC-965	PILASTER CAP	39
SMC-342	CASING - 342	8	SMC-124	COVE MOULDING	44	SMC-960	PILASTER CAP	39
SMC-343	CASING - 343	7	SMC-180	CROWN MLD - 2x4 RAKE	38	SMC-980	PILASTER	39
SMC-344	CASING - 344	8	SMC-181	CROWN MLD - 2x4 RAKE	38	SMC-350P	PLINTH - BENTON	11
SMC-345	CASING - 345	8	SMC-720	CROWN MOULDING - CONTEMP.	28	SMC-340P	PLINTH - HERMAN	11
SMC-347	CASING - 346	9	SMC-730	CROWN MOULDING - CONTEMP.	28	SMC-260	QUARTER ROUND	44
SMC-348	CASING - 347	9	SMC-170	CROWN MLD - CURTIS	18	SMC-263	QUARTER ROUND	44
SMC-357	CASING - 357	10	SMC-160	CROWN MLD - CURTIS	18	SMC-265	QUARTER ROUND	44
SMC-358	CASING - 358	10	SMC-110	CROWN MOULDING	17	SMC-267	QUARTER ROUND	44
SMC-359	CASING - 359	10	SMC-113	CROWN MOULDING	17	SMC-050	SHOE MOULDING	30
SMC-442	CASING - 442	7	SMC-114	CROWN MOULDING	17	SMC-942	SIDING - BEADED	36
SMC-444	CASING - 444	7	SMC-115	CROWN MOULDING	17	SMC-946	SIDING - BEVELED	36
SMC-445	CASING - 445	7	SMC-120	CROWN MOULDING	17	SMC-951	SIDING - GERMAN	36
SMC-346	CASING - BARRUS	9	SMC-130	CROWN MOULDING	17	SMC-955	SIDING - SHIPLAP	36
SMC-350	CASING - BENTON	5	SMC-118	CROWN MOULDING	23	SMC-530	STOOL WINDOW - BEVEL RAB	13
SMC-355	CASING - BEVEL	6	SMC-112	CROWN MOULDING	23	SMC-540	STOOL WINDOW - FLAT RAB	13
SMC-356	CASING - BEVEL	6	SMC-700	CROWN MOULDING	28	SMC-520	STOOL WINDOW - NO RAB	13
SMC-351	CASING - CLAMHELL	6	SMC-701	CROWN MOULDING	28	SMC-080	STOP - BEADED	14
SMC-352	CASING - CLAMHELL	6	SMC-915	CROWN SOLID BACK	41	SMC-075	STOP - OG	14
SMC-336	CASING - COAST GUARD	8	SMC-486	DENTIL MOULDING - BEADED	25	SMC-078	T-ASTRAGAL	49
SMC-390	CASING - CONTEMPORARY	28	SMC-485	DENTIL MOULDING	25	SMC-088	KERFED ASTRAGAL	49
SMC-349	CASING - FLUTED	8	SMC-361	DRIP CAP	35			
SMC-335	CASING - FRANKLIN	7	SMC-362	DRIP CAP	35			
SMC-323	CASING - GLENWOOD	6	SMC-850	FLOORING - T&G	48			
SMC-339	CASING - HERMAN BEADED	4	SMC-251	HALF ROUND	49			
SMC-330	CASING - HERMAN	4	SMC-6010	HANDRAIL	42			
SMC-340	CASING - HERMAN	4	SMC-604	HANDRAIL	42			

Stock Number	Moulding Description	PG	Stock Number	Moulding Description	PG	Stock Number	Moulding Description	PG
SMC-010	BACKBAND - RND EDGE	5	SMC-260	QUARTER ROUND	44	SMC-560	APRON - BENTON	13
SMC-015	BACKBAND - OG	5	SMC-263	QUARTER ROUND	44	SMC-561	APRON - BENTON MLD	13
SMC-020	BACKBAND - BENTON	5	SMC-265	QUARTER ROUND	44	SMC-595	COVE MLD - SCOTIA	45
SMC-025	BACKBAND - OG	5	SMC-267	QUARTER ROUND	44	SMC-596	COVE MLD - SCOTIA	45
SMC-026	BACKBAND	9	SMC-300	CASING - MOULDED	4	SMC-600	BARRAIL	43
SMC-027	BACKBAND	9	SMC-310	CASING - MOULDED	4	SMC-601	HANDRAIL	42
SMC-030	BACKBAND - BENTON	5	SMC-320	CASING - MOULDED	4	SMC-6010	HANDRAIL	42
SMC-050	SHOE MOULDING	30	SMC-321	CASING - OGEE	6	SMC-602	HANDRAIL	43
SMC-060	PANEL MOULDING - BENTON	49	SMC-322	CASING - REEDED	6	SMC-603	HANDRAIL	43
SMC-065	PANEL MOULDING	49	SMC-323	CASING - GLENWOOD	6	SMC-604	HANDRAIL	42
SMC-070	PANEL MOULDING	49	SMC-330	CASING - HERMAN	4	SMC-6040	HANDRAIL	42
SMC-075	STOP - OG	14	SMC-335	CASING - FRANKLIN	7	SMC-605	HANDRAIL	43
SMC-077	PICTURE MOULD	49	SMC-336	CASING - COAST GUARD	8	SMC-606	HANDRAIL	43
SMC-078	T-ASTRAGAL	49	SMC-339	CASING - HERMAN BEADED	4	SMC-650	BASE - SPEED	29
SMC-080	STOP - BEADED	14	SMC-340	CASING - HERMAN	4	SMC-700	CROWN MOULDING	28
SMC-088	KERFED ASTRAGAL	49	SMC-340P	PLINTH - HERMAN	11	SMC-701	CROWN MOULDING	28
SMC-101	BED MOULDING	16	SMC-341	CASING - 341	7	SMC-702	BED MOULDING	28
SMC-102	BED MOULDING	16	SMC-342	CASING - 342	8	SMC-703	OG MOULDING	28
SMC-103	BED MOULDING	16	SMC-343	CASING - 343	7	SMC-704	NECK MOULDING	28
SMC-104	BED MOULDING	16	SMC-344	CASING - 344	8	SMC-705	COVE MOULDING	28
SMC-105	BED MOULDING	24	SMC-345	CASING - 345	8	SMC-706	MODILLION BLOCK	37
SMC-109	BED MOULDING - w/LEG	16	SMC-346	CASING - BARRUS	9	SMC-707	MODILLION PLATE	37
SMC-110	CROWN MOULDING	17	SMC-346B	BACKBAND - BARRUS	9	SMC-708	MODILLION MOULDING	37
SMC-112	CROWN MOULDING	23	SMC-347	CASING - 346	9	SMC-709	MODILLION BLOCK	37
SMC-113	CROWN MOULDING	17	SMC-348	CASING - 347	9	SMC-720	CROWN MOULDING - CONTEMP.	28
SMC-114	CROWN MOULDING	17	SMC-349	CASING - FLUTED	8	SMC-730	CROWN MOULDING - CONTEMP.	28
SMC-115	CROWN MOULDING	17	SMC-350	CASING - BENTON	5	SMC-820	BASE - OG	29
SMC-118	CROWN MOULDING	23	SMC-350P	PLINTH - BENTON	11	SMC-830	BASE - BENTON	29
SMC-120	CROWN MOULDING	17	SMC-351	CASING - CLAMSHELL	6	SMC-838	BASE - CONTEMPORARY	28
SMC-121	COVE MOULDING	44	SMC-352	CASING - CLAMSHELL	6	SMC-840	PANELING - T&G BEADED DBL	48
SMC-122	COVE MOULDING	44	SMC-353	CASING - RANCH	6	SMC-850	FLOORING - T&G	48
SMC-123	COVE MOULDING	44	SMC-354	CASING - RANCH	6	SMC-860	PANELING - T&G V GROOVE	47
SMC-124	COVE MOULDING	44	SMC-355	CASING - BEVEL	6	SMC-864	PANELING - T&G V GROOVE DBL	47
SMC-125	COVE MOULDING	20	SMC-356	CASING - BEVEL	6	SMC-870	PANELING - INSERT	47
SMC-126	COVE MOULDING	19	SMC-357	CASING - 357	10	SMC-871	PANELING - PICKWICK	47
SMC-127	COVE MOULDING	19	SMC-358	CASING - 358	10	SMC-880	PANELING - T&G BEADED	48
SMC-128	COVE MOULDING	19	SMC-359	CASING - 359	10	SMC-890	PANELING - T&G BEADED	48
SMC-130	CROWN MOULDING	17	SMC-360	BRICK MLD - ANDERSEN	35	SMC-895	PANELING - T&G QTR RND	48
SMC-140	COVE MOULDING	22	SMC-361	DRIP CAP	35	SMC-900	HEAD MOULD	40
SMC-141	COVE MOULDING	22	SMC-362	DRIP CAP	35	SMC-910	MANTLE SURROUND	41
SMC-142	COVE MOULDING	22	SMC-365	APRON - WINDOW SILL	35	SMC-915	CROWN SOLID BACK	41
SMC-143	COVE MOULDING	24	SMC-370	BRICK MLD - BEADED	35	SMC-920	MANTLE SURROUND	41
SMC-146	COVE MOULDING	20	SMC-390	CASING - CONTEMPORARY	28	SMC-925	MANTLE SURROUND	40
SMC-147	COVE MOULDING	20	SMC-410	BASE CAP - OG	30	SMC-930	MANTLE MOULDING	41
SMC-160	CROWN MLD - CURTIS	18	SMC-411	BASE CAP - RABBETED	30	SMC-935	MANTLE MOULDING	41
SMC-163	BASE CAP	30	SMC-412	BASE CAP - RABBETED	30	SMC-942	SIDING - BEADED	36
SMC-170	CROWN MLD - CURTIS	18	SMC-414	BASE CAP - OG SKIRT	30	SMC-945	MANTLE BREAST	40
SMC-180	CROWN MLD - 2x4 RAKE	38	SMC-420	BASE CAP - BENTON	30	SMC-946	SIDING - BEVELED	36
SMC-181	CROWN MLD - 2x4 RAKE	38	SMC-430	BASE CAP - BEVEL	30	SMC-951	SIDING - GERMAN	36
SMC-190	CORNER MOULDING OUTSIDE	44	SMC-440	BASE CAP - HERMAN	30	SMC-955	SIDING - SHIPLAP	36
SMC-191	CORNER MOULDING OUTSIDE	44	SMC-442	CASING - 442	7	SMC-955	MANTLE BREAST	40
SMC-192	CORNER MOULDING OUTSIDE	44	SMC-444	CASING - 444	7	SMC-960	PILASTER CAP	39
SMC-193	CORNER BEAD	45	SMC-445	CASING - 445	7	SMC-965	PILASTER CAP	39
SMC-194	CORNER BEAD	45	SMC-450	BASE CAP - OG	30	SMC-966	PILASTER BASE	39
SMC-195	CORNER BEAD	45	SMC-460	MULLION BENTON	14	SMC-970	NECK MOULDING	39
SMC-200	CHAIR RAIL	33	SMC-470	MULLION BEADED	14	SMC-975	MANTLE CROWN	40
SMC-205	CHAIR RAIL - BARRUS	33	SMC-474	BEADED TWO EDGE	32	SMC-980	PILASTER	39
SMC-210	CHAIR RAIL	33	SMC-485	DENTIL MOULDING	25	SMC-990	LANDING NOSING	45
SMC-220	CHAIR RAIL	33	SMC-486	DENTIL MOULDING - BEADED	25	SMC-RB3	CASING - RB3	8
SMC-230	CHAIR RAIL - RABBETED	33	SMC-491	BEADED ONE EDGE	38			
SMC-240	CHAIR RAIL - BENTON	32	SMC-496	BEADED ONE EDGE	38			
SMC-241	CHAIR RAIL - BENTON	32	SMC-520	STOOL WINDOW - NO RAB	13			
SMC-241A	CHAIR RAIL - BENTON	32	SMC-530	STOOL WINDOW - BEVEL RAB	13			
SMC-242	CHAIR RAIL - SPECIAL	33	SMC-540	STOOL WINDOW - FLAT RAB	13			
SMC-251	HALF ROUND	49	SMC-550	APRON - WINDOW	13			

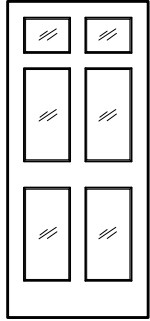

F66

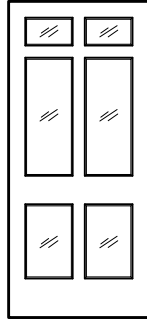

ND108

STOCK and CUSTOM
STORM DOORS

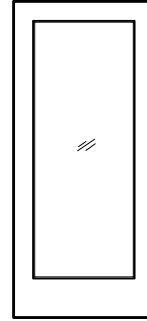

1 LITE

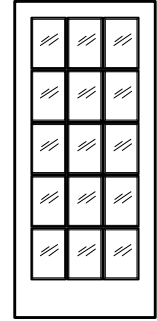

15 LITE

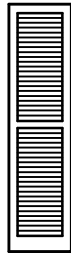
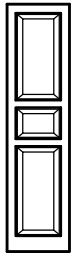
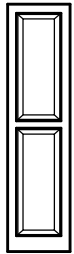

EXTERIOR BLINDS



5/8" GLASS

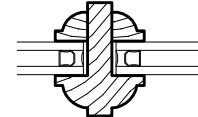

1/2" GLASS

MUNTINS

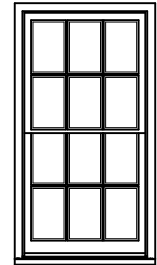

WINDOW UNITS

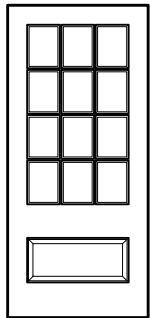

ND512

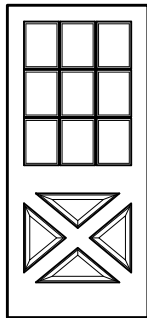

ND612

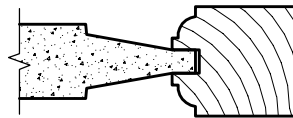

1 3/4" STILE & RAIL STICKING
1 3/16" HIP RAISED PANEL

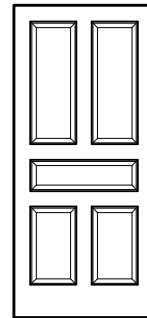

5PNL

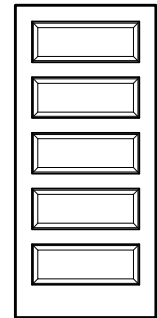

F55

20 - MINUTE LABEL FRAMES

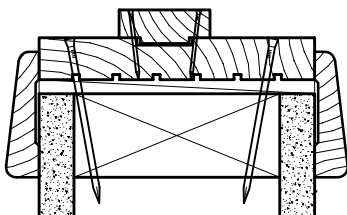

T-STOP

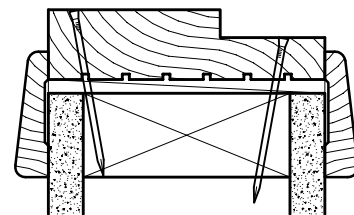

RABBETED

THIS PAGE NOT TO SCALE

Solid Wood Storm Doors

Available in 1 1/8" and 1 3/8" material. Multiple options for glass and species. Custom sizes and layout.

Exterior Louver and Raised Panel Shutters

Available in N.C. Pine, Redwood, Western Red Cedar, and Paint Grade Mahogany. Able to duplicate existing shutters.

Stile and Rail Raised Panel and Glass Doors

We manufacture these items from most species of lumber including Fir, Oak, Poplar, Cherry, Mahogany, and Walnut. True divided light, insulated and single pane glass. Suitable for exterior and interior applications. Available in 1 3/8", 1 3/4", 2" and 2 1/4" material. Designed to your specifications.

Window Sash and Custom Window Units

We can match most custom profile sash. All sash true divided light.

Available in insulated and single pane glass.

Complete double hung window units with weather-stripping and balances, as well as weight and cord units.

Solid Wood 20-Minute Label Inside Door Jambs

20-Minute Rabbeted or T-Stop Jambs. Pre-machined for hinges and strike.

Woodlife Treating

All exterior millwork products woodlife treated.

Custom Detailing Department

Complete CAD design service. Detailed drawings available for all of your custom product requirements.





Since 1946, Stephenson Millwork has been recognized as a leader in quality woodworking. With our vast experience in wood moldings, we are well equipped to provide stock and custom moldings in a wide selection of lumber species.



AWI ARCHITECTURAL
WOODWORK
INSTITUTE

Stephenson
MILLWORK COMPANY, INC.

WILSON

P.O. Box 699 • 210 Harper Street
Wilson, North Carolina 27894
Tel: 252-237-1141 • Fax: 252-237-4377

email: smcinc@smcinc.com

RALEIGH

1053 E. Whitaker Mill Road, Suite 165
Raleigh, North Carolina 27604
Tel: 919-829-1005 • Fax: 919-829-7030

web: www.smcinc.com